

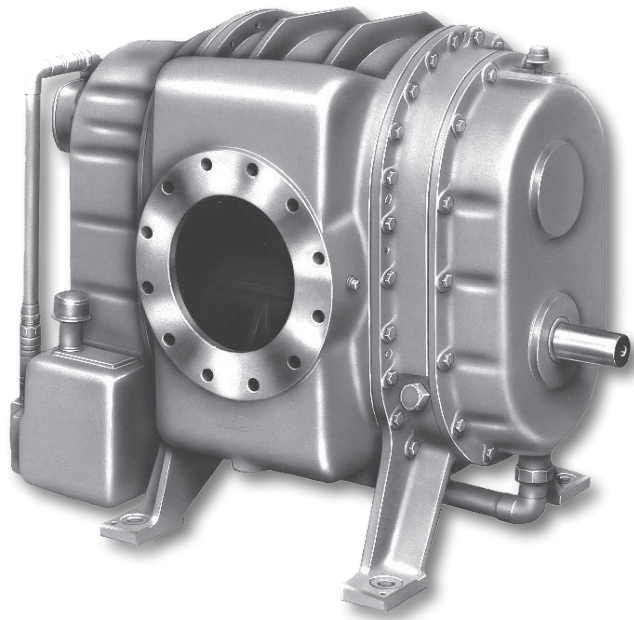

# Roots® RAS, RGS, & RAS-J Blower - 10"-20" Pressure Lubricated Installation and Operation Manual





## Contents

Information Summary .....	3	Preventive Maintenance .....	20
Operating Characteristics .....	4	Vibrations .....	21
Operating Limitations .....	5	Steam Service .....	22
Installation .....	8	High Vacuum Booster Service .....	24
Lubrication .....	15	Maintenance/Replacements .....	25
Operation .....	17	Troubleshooting and Repairs .....	26
Troubleshooting Checklist .....	18	Parts List .....	27
Safety Precautions .....	19	Assembly Drawings .....	28

## Information Summary

### Do These Things To Get The Most From Your Roots Blower from Roots

- o Check shipment for damage. If found, file claim with carrier and notify nearest Roots Sales Office.
- o Unpack shipment carefully, and check contents against Packing List. Notify Sales Office if a shortage appears.
- o Store in a clean, dry location until ready for installation. Lift by methods discussed under INSTALLATION to avoid straining or distorting the equipment. Keep covers on all openings. Protect against weather and corrosion if outdoor storage is necessary.
- o Read LIMITATIONS and INSTALLATION sections in this manual and plan the complete installation.
- o Provide for adequate safeguards against accidents to persons working on or near the equipment during both installation and operation. See SAFETY PRECAUTIONS.
- o Install all equipment correctly. Foundation design must be adequate and piping carefully done. Use recommended accessories for operating protection.
- o Make sure both driving and driven equipment is correctly lubricated before start-up. See LUBRICATION.
- o Read starting check points under OPERATION. Run equipment briefly to check for obvious faults, and make corrections. Follow with a trial run under normal operating conditions.
- o In the event of trouble during installation or operation, do not attempt repairs of Roots Roots furnished equipment. Notify nearest Sales Office giving all nameplate information plus an outline of operating conditions and a description of the trouble.
- o Unauthorized attempts at equipment repair may void Manufacturer's warranty. It is recommended that such work be limited to the operations described in this manual, using Factory Parts. Good inspection and maintenance practices should reduce the need for repairs.

Note – Information in this manual is correct as of the date of publication. The Manufacturer reserves the right to make design or material changes without notice, and without obligation to make similar changes on equipment of prior manufacture.

## Operating Characteristics

Roots's Roots units covered in this manual range in basic size from 10 inches through 20 inches gear diameter. From a usage or application standpoint there are two general types. Type RAS/RAS Whispair units from Roots are designated as air blowers, and may be used for handling air or some gases where leakage to atmosphere is not objectionable. Type RGS/RGS Whispair units are similar in basic design, but include seal modifications necessary for the handling of gases where leakage needs to be reduced to a practical minimum.

For simplicity, the term "blower" is used generally in this manual to refer to either type of unit. Where statements or data do not apply equally to both, the terms "air blower" and "gas blower" are used for identification. The Roots rotary lobe blower from Roots is a positive displacement type unit whose pumping capacity is determined by size, operating speed and pressure conditions. It employs two double-lobe impellers mounted on parallel shafts and rotating in opposite directions within a cylinder closed at the ends by headplates. As the impellers rotate, air or gas is drawn into one side of the cylinder and forced out the opposite side against the existing pressure. The pressure developed, therefore, depends on the resistance of the discharge system. Effective sealing of the blower inlet area from the discharge area is accomplished by use of very small operating clearances. There is no metal-to-metal contact so internal lubrication is not required. Clearances between the impellers during rotation are maintained by a pair of accurately machined timing

gears, mounted on the two shafts extending outside the air chamber blower casing.

Operation of the familiar basic rotary lobe blower is illustrated in Figure 1, where air flow is left to right with the lower impeller rotating counterclockwise. In Position 1, it is delivering a known volume (A) to the discharge, while space (B) between the upper impeller and cylinder wall is being filled. Clockwise rotation of this impeller then traps equal volume (B) in Position 2, and further rotation delivers it to the discharge in Position 3. At the same time, another similar volume is forming under the lower impeller, and will be discharged when rotation reaches Position 1 again.

One complete revolution of the driving shaft alternately traps four equal and known volumes of air (two by each impeller) and pushes them through to the discharge. The pumping capacity of a lobe blower operating at constant speed therefore remains relatively independent of reasonable inlet or discharge pressure variations. To change capacity, it is necessary either to change speed of rotation or vent some of the air.

Operation of the proprietary RAS/RGS Whispair design blower from Roots is represented in Figure 2. Air flow again is left to right, with the lower shaft rotation counterclockwise. This design differs from the basic type rotary blower in that it provides a chamber on the discharge side of the cylinder.

From this chamber two or more slots open back into

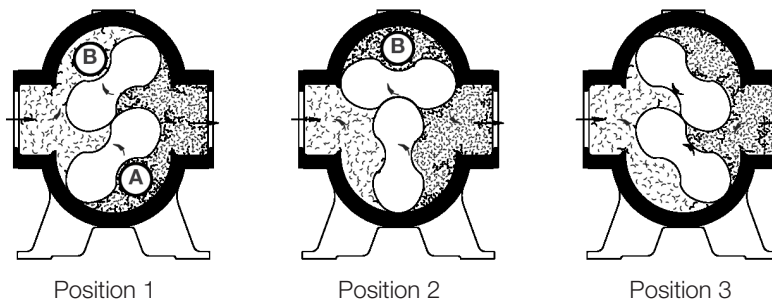

**Figure 1** - Flow Through a Basic Type RAS/RGS Blower

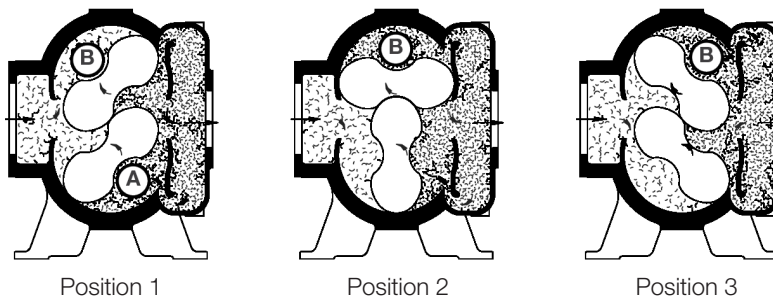

**Figure 2** -Flow Through a RAS/RGS Whispair Blower

## Operating Characteristics (Cont'd)

the two alternately closed pocket areas of the cylinder, shown as A and B. These slots, at certain impeller positions, allow discharge pressure to bleed into the normally low pressure pockets. They also provide a jet action on the impellers in the direction of rotation. Gradual pressure build-up in the pockets, to a level almost equal to the discharge pressure, reduces backflow rate at the instant of pocket discharge so that pulsing and shock noise are minimized.

Considering Position 1 in Figure 2, known volume (A) is being delivered to the discharge chamber while space (B) is being filled with an equal volume at inlet pressure. In Position 2, this space has been sealed off from the inlet, but some discharge pressure is now entering space (B) through the slot passage, as indicated by the small arrows. Force of this jet gives a rotative assist to the impeller, while also building pressure in sealed space (B). Rotation continues to Position 3, where volume (B) is delivered to the discharge chamber in the same manner as volume (A) in Position 1. Because of the almost complete pressure equalization through the slot, shock is minimized.

With either blower design, no attempt should ever be made to control capacity by means of a throttle valve in the intake or discharge piping. This increases the power load on the driver, and may seriously damage the blower. Likewise, if a possibility exists that flow to the blower inlet may be cut off during normal operation of a process, then an adequate vacuum relief valve should be installed in the inlet in the line near the blower. A pressure type relief valve in the discharge line near the blower is also strongly recommended for protection against cut-off or blocking in this line.

When a belt drive is employed, blower speed can usually be adjusted to obtain desired capacity by changing the diameter of one or both sheaves. In a direct coupled arrangement, a variable speed motor or transmission is required, or air may be vented through a manually controlled unloading valve and silencer. If discharge air is returned to the blower inlet, it must go through a cooling by-pass arrangement.

**Before making any changes in blower capacity or operating conditions**, contact the nearest Sales Office for specific information applying to your particular blower. In all cases, operating conditions must be maintained within the approved range of pressures, temperatures and speeds as stated under **LIMITATIONS**. Also, the blower **must not be used to handle air containing liquids or solids**. Serious damage to the rotating parts will result.

## Operating Limitations

To establish and maintain continued satisfactory performance, any Roots blower from Roots must be operated within certain approved limiting conditions. The Manufacturer's warranty is, of course, contingent on such operation.

RAS/RGS and RAS/RGS WHISPAIR blowers from Roots are available with two types of internal blower clearances, normal and open. Table 1 lists maximum pressure, temperature, vacuum and speed limits for both types of clearances. Do not exceed any one or combinations of limits listed in Table 1.

Example: the listed maximum allowable temperature rise (increase in air temperature between inlet and discharge) for any particular blower may occur well before maximum speed or maximum pressure rating is reached. Temperature rise then is the limiting condition. In other words, the operating limit is always to be determined by the maximum rating reached first. It can be any one of the three: pressure, temperature or speed.

Be sure to arrange connections or taps for thermometers and pressure or vacuum gauges at or near the inlet and discharge connections of the blower. These, along with a good tachometer, will enable periodic checks of operating conditions to be made easily.

Note: Some special purpose blowers may be assembled with non-standard clearances. These units may be operated at pressure and or temperature rises higher than those listed in applicable Table 1. Before doing so, however, request specific approval from the nearest Sales Office. Normally, when a blower is operated at the design conditions stamped on its nameplate, the specified limits apply.

**Pressure:** On pressure service, the pressure rise in pounds per square inch (kPa) between blower inlet and discharge, must not exceed the figure listed for the specific blower and frame size concerned. Also, in any system where the blower inlet is at a positive pressure above atmosphere, the discharge pressure must never exceed 25 PSI (172 kPa) gauge regardless of blower size.

**Vacuum:** On vacuum service with the discharge going to atmospheric pressure, the inlet suction or vacuum in inches of mercury (kPa) must not be greater than the values listed for the specific frame size.

**Temperature:** Various blower frame sizes are approved only for installations where the following temperature limitations can be maintained in service.

A. Maximum temperature rise (T.R.) in Fahrenheit degrees (° C) must not exceed listed values when the inlet is at ambient temperatures. Ambient is considered as the general temperature of the space around the blower.

Table 1A - Maximum Allowable Operating Conditions (22 PSL)

Frame Size	Speed RPM	Normal Clearances - RP68						Open Clearances - RP71					
		Pressure Rise		Inlet Vacuum		Temperature Rise		Pressure Rise		Inlet Vacuum		Temperature Rise	
		PSI	kPa	Inches Hg.	kPa	°F	°C	PSI	kPa	Inches Hg.	kPa	°F	°C
1006	1900	36.6	252	16	54	205	96	36.6	252	16	54	300	149
1009	1900	24.4	168	16	54	205	96	24.4	168	16	54	280	138
1012	1900	18.3	126	16	54	205	96	18.3	126	16	54	280	138
1016	1900	13.3	92	16	54	148	64	13.3	92	16	54	240	116
1018	1900	11.7	81	16	54	148	64	11.7	81	16	54	240	116
1021	1900	10.4	72	16	54	148	64	10.4	72	16	54	240	116
1024	1900	9.2	63	16	54	148	64	9.2	63	16	54	240	116
1030	1900	7.3	50	15	51	148	64	7.3	50	15	51	240	116
1212	1600	22.0	152	16	54	223	106	22.0	152	16	54	280	138
1216	1600	16.5	114	16	54	223	106	16.5	114	16	54	280	138
1220	1600	13.2	91	16	54	148	64	13.2	91	16	54	235	113
1222	1600	11.7	81	16	54	148	64	11.7	81	16	54	235	113
1225	1600	10.5	72	16	54	148	64	10.5	72	16	54	235	113
1228	1600	9.2	63	16	54	148	64	9.2	63	16	54	235	113
1236	1600	7.3	50	15	51	148	64	7.3	50	15	51	235	113
1412	1365	24.6	170	16	54	230	110	24.6	170	16	54	280	138
1414	1365	21.2	146	16	54	230	110	21.2	146	16	54	280	138
1418	1365	16.6	114	16	54	230	110	16.6	114	16	54	280	138
1422	1365	13.7	94	16	54	140	60	13.7	94	16	54	230	110
1425	1365	12.2	84	16	54	140	60	12.2	84	16	54	230	110
1428	1365	11.0	76	16	54	140	60	11.0	76	16	54	230	110
1431	1365	9.8	68	16	54	140	60	9.8	68	16	54	230	110
1435	1365	8.8	61	16	54	140	60	8.8	61	16	54	230	110
1442	1365	7.3	50	15	51	140	60	7.3	50	15	51	230	110
1616	1200	22.0	152	16	54	230	110	22.0	152	16	54	280	138
1620	1200	17.6	121	16	54	230	110	17.6	121	16	54	280	138
1625	1200	14.0	97	16	54	230	110	14.0	97	16	54	280	138
1627	1200	13.0	90	16	54	140	60	13.0	90	16	54	230	110
1630	1200	11.7	81	16	54	140	60	11.7	81	16	54	230	110
1633	1200	10.6	73	16	54	140	60	10.6	73	16	54	230	110
1636	1200	9.8	68	16	54	140	60	9.8	68	16	54	230	110
1639	1200	9.0	62	16	54	140	60	9.0	62	16	54	230	110
1643	1200	8.2	57	16	54	140	60	8.2	57	16	54	230	110
1645	1200	7.8	54	16	54	140	60	7.8	54	16	54	230	110
1648	1200	7.3	50	15	51	140	60	7.3	50	15	51	230	110
1821	1060	18.8	130	16	54	230	110	18.8	130	16	54	280	138
1824	1060	16.5	114	16	54	230	110	16.5	114	16	54	280	138
1827	1060	14.6	101	16	54	230	110	14.6	101	16	54	280	138
1830	1060	13.2	91	16	54	140	60	13.2	91	16	54	230	110
1833	1060	11.7	81	16	54	140	60	11.7	81	16	54	230	110
1838	1060	10.4	72	16	54	140	60	10.4	72	16	54	230	110
1841	1060	9.6	66	16	54	140	60	9.6	66	16	54	230	110
1845	1060	8.8	61	16	54	140	60	8.8	61	16	54	230	110
1849	1060	8.0	55	16	54	140	60	8.0	55	16	54	230	110
1854	1060	7.3	50	15	51	140	60	7.3	50	15	51	230	110
2022	1000	19.6	135	16	54	225	107	19.6	135	16	54	280	138
2026	1000	14.7	101	16	54	135	57	14.7	101	16	54	225	107
2030	1000	14.7	1010	16	54	135	57	14.7	101	16	54	225	107
2033	1000	13	90	16	54	135	57	13	90	16	54	225	107
2037	1000	11.7	81	16	54	135	57	11.7	81	16	54	225	107
2040	1000	11	76	16	54	135	57	11	76	16	54	225	107
2044	1000	10	69	16	54	135	57	10	69	16	54	225	107
2047	1000	9.4	65	16	54	135	57	9.4	65	16	54	225	107
2050	1000	8.8	61	16	54	135	57	8.8	61	16	54	225	107
2055	1000	7.9	54	16	54	135	57	7.9	54	16	54	225	107
2057	1000	7.7	53	16	54	135	57	7.7	53	16	54	225	107
2060	1000	7.3	50	15	51	135	57	7.3	50	15	51	225	107

**Table 1B - Maximum Allowable Operating Conditions (40 PSL)**

Frame Size	Speed RPM	Normal Clearances - RP68						Open Clearances - RP71					
		Pressure Rise		Inlet Vacuum		Temperature Rise		Pressure Rise		Inlet Vacuum		Temperature Rise	
		psi	kPa	Inches Hg.	kPa	°F	°C	PSI	kPa	Inches Hg.	kPa	°F	°C
2022	1000	36.3	250	16	54	225	125	36.3	250	16	54	280	155
2026	1000	30.7	211	16	54	225	125	30.7	211	16	54	280	155
2028.5	1000	28.0	193	16	54	225	125	28.0	193	16	54	280	155
2030	1000	26.7	184	16	54	225	125	26.7	184	16	54	280	155
2033	1000	24.2	167	16	54	135	75	24.2	167	16	54	225	125
2037	1000	21.3	147	16	54	135	75	21.3	147	16	54	225	125
2040	1000	20.0	138	16	54	135	75	20.0	138	16	54	225	125
2044	1000	18.1	125	16	54	135	75	18.1	125	16	54	225	125
2047	1000	17.0	117	16	54	135	75	17.0	117	16	54	225	125
2050	1000	16.0	110	16	54	135	75	16.0	110	16	54	225	125
2053	1000	15.0	104	16	54	135	75	15.0	104	16	54	225	125
2055	1000	14.5	100	16	54	135	75	14.5	100	16	54	225	125
2057	1000	14.0	97	16	54	135	75	14.0	97	16	54	225	125
2060	1000	13.3	92	16	54	135	75	13.3	92	16	54	225	125
2062	1000	12.9	89	16	54	135	75	12.9	89	16	54	225	125
2064	1000	12.5	86	16	54	135	75	12.5	86	16	54	225	125
2070	1000	11.4	79	16	54	135	75	11.4	79	16	54	225	125
2072	1000	11.1	77	16	54	135	75	11.1	77	16	54	225	125
2077	1000	10.4	72	16	54	135	75	10.4	72	16	54	225	125
2080	1000	10.0	69	16	54	135	75	10.0	69	16	54	225	125

Note: If material of construction for impeller or casing is stainless steel, temperature rise limits are reduced by 50%. Only Open Clearance, RP-71, is used with stainless steel construction and typical limit is 120°F (67°C)

## Operating Limitations (Cont'd)

This is not outdoor temperature unless the blower is installed outdoors.

- B. If inlet temperature is higher than ambient, the listed allowable temperature rise values must be reduced by 2/3 of the difference between the actual measured inlet temperature and the ambient temperature.

Speed Range-Blowers may be operated at speeds up to the maximums listed for the various frame sizes. They may be direct coupled to suitable constant speed drivers if pressure/temperature conditions are also within limits. At lower speeds, excessive temperature rise may be the limiting factor.

### Installation

Technical assistance at installation by a Factory Service Engineer is usually not required for the smaller units, frame series 1000 through 1400. Workers with general experience in installing heavy machinery should be able to complete a satisfactory installation. Information in this manual is supplemented by the more detailed discussions of foundations and piping in Compressed Air and Gas Handbook published by the Compressed Air and Gas Institute, New York City. However, a Service Engineer may be employed for assistance or for final checking of an installation.

Handling of the equipment should be accomplished by methods conforming to safe practice for the weight involved. Weight of a bare unit, without base plate, driver or accessories will range from about 1 ton (910 kg) for the smallest to approximately 7 tons (6350 kg). On such units, an eyebolt is provided near each end for lifting. A unit mounted on a base plate should be lifted only by the four lifting lugs provided in the baseplate. Weight in this case will be greater than the above figures.

Before lifting with eyebolts, test each one for tightness and fractures by tapping with a hammer. Direction of pull on the bolts during lift should be nearly vertical. Since a considerable cable angle will usually be unavoidable, place a stiff spreader between the eyebolts to take the side strain, and adjust cable lengths so that the unit is approximately level during the lift. A harness featuring four lifting hooks is required to lift base-mounted units. After inserting the hooks in the lifting lugs, block the chains out on the sides to avoid placing the unit under strain. At the same time, adjust lengths to produce a level lift.

**LOCATION** of the installation is generally not a critical matter. A clean, dry and protected indoor location is to be preferred. However, an outdoor location will give satisfactory service if correct lubrication for expected temperatures is provided. Effect of such a location on driver and other equipment must also be considered.

**PROTECTION** of internal machined surfaces against normal atmospheric corrosion has been provided at the factory, using a vaporizing inhibitor. Maximum period of protection is one year under average conditions, if flange covers and closing seals are not removed. Protection against chemical or salt water atmosphere is not provided. Leave covers and tape seals over all openings as long as possible during installation to avoid loss of protection.

If there is to be an extended period between installation and start up, the following steps should be taken to insure corrosion protection:

- 1 Coat internals of cylinder, gearbox and drive end bearing covers with Motorstor or equivalent. Repeat once a year or as conditions may require. Motorstor is oil soluble and does not have to be removed before lubricating. If desired, Motorstor may be removed from within the cylinder shortly before start up by spraying a fine mist of petroleum solvent through the blower while it is running at a slow speed with open inlet and discharge, or it can remain in the blower if it is not harmful to the operation of the connected system. Motorstor is a product of Daubert Chemical Co., 2000 Spring Ed., Oak Brook, IL 60521.
- 2 Paint shaft extension, inlet and discharge flanges, and all other exposed surfaces with Nox-Rust X-145 or equivalent.
- 3 Seal inlet, discharge, and vent openings. It is not recommended that the unit be set in place, piped to the system, and allowed to remain idle for extended periods. If any part is left open to the atmosphere, the Motorstor vapor will escape and lose its effectiveness.
- 4 Units are not to be subjected to excessive vibration during storage. If stored outdoors, provide coverage such as a tarpaulin or lean-to.
- 5 Rotate drive shaft three or four revolutions every two weeks.
- 6 Prior to start up, remove flange covers on both inlet and discharge and inspect internals to insure absence of rust. Check all internal clearances. Also, at this time, remove gearbox and bearing covers and inspect gear teeth and bearings for rust.

When ready to connect piping, remove main flange covers and inspect blower interior for presence of foreign particles or dirt adhering to machined surfaces. Clean out such material by washing carefully with a petroleum solvent, then rotate impellers manually to make sure they turn freely. Also use the same solvent to remove the anti-rust coating from flange faces and any other surfaces. Note: interior cleaning is not required if no dirt is found.



## Installation (Cont'd)

**FOUNDATION** design depends on local soil conditions and several other factors and can only be discussed generally here. Additional information will be found in the publication referred to at the beginning of this section. For satisfactory operation of supported equipment, a concrete foundation must be rigid, must have minimum deflections, and must be free from resonant frequencies in the operating speed range of the equipment.

Length and width dimensions of the foundation should provide at least 6 inches (150 mm) from any edge to the nearest machine anchor bolt, as located from the **certified** manufacturer's general arrangement drawing. Depth dimension should be determined by design, but a minimum practical depth is considered to be twice the distance between shaft centers (or gear diameter) of the unit. This would put at least 24 inches (610 mm) of concrete under a frame series 1200 unit, such as a 1225. The concrete block should be permitted to cure for a minimum of 28 days before the blower is grouted in place. Any block distortions during curing then will have little or no affect on equipment and alignment. To simplify machine leveling and provide good grouting bond, the top of the foundation should be struck off as level as possible but left with a rough surface.

Spring-type vibration isolating mountings are **not recommended** for use directly between the operating equipment and the foundation. Where such mountings are required, they should be designed to carry a reinforced concrete slab on which the equipment is mounted. This slab must have good rigidity against bending and twisting, and the suspension system will require careful adjustment to produce a reasonably level condition during operation. All piping will require flexible sections and supports to reduce connection strains on the unit to a minimum.

Direct use of structural framing members for mounting is **not recommended**. If unavoidable, it should be restricted to units of the smaller frame sizes, and spring-type mountings should not be used. Structural members must be rigid, and will probably require reinforcement if part of a building. Noise transmission can be reduced by use of a cork isolating pad. This can be 1 to 2 inch (25-50 mm) thickness, bedding on a full steel plate attached to the structure and carrying rigid concrete slab on which the equipment is mounted.

**ANCHOR BOLTS** are to be placed within the foundation forms before concrete is poured. Hook-type bolts installed as shown in Figure 3, with diameter and length as in Table 2, are recommended. The bolts must be located as accurately as possible from dimensions on certified installation drawing. To obtain

a bolt location tolerance of 1/8" (3 mm), use of drilled templates firmly secured to the foundation forms is recommended.

The bolt sleeves shown, if kept centered around the bolts and free of concrete, will allow bolts to be sprung enough to correct for small variations in bolt setting and machine drilling. The sleeves are filled in the final grouting operation.

Bolt positions should be adjusted vertically so that the top ends will extend at least 1-1/2 diameters above the soleplate or taper washer, or as shown on the installation drawing.

Jack screws are provided to make leveling the height adjustments easier. Steel plates, approximately 4" x 4" x 1/2" (100 x 100x 13mm), should be placed on the foundation under each jack screw location. Plates and anchor bolts are not furnished as standard accessories.

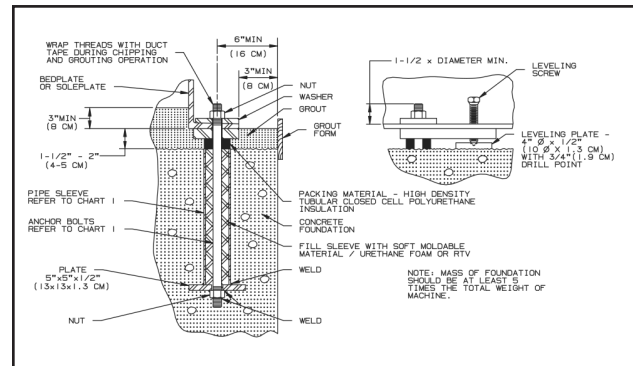

Figure 3 - Typical Anchor Bolt Detail

**LEVELING** is very important and should be performed with care, using a good machinist's level having a ground glass bubble vial. A setting as level as possible in all directions is the desired result.

When blower and driver have been factory mounted on a common baseplate, the assembly is to be treated as a unit for leveling purposes. Use the jack screws to establish grouting space under the base flanges, and to level the base. Adjust these screws until the indicated variation from level does not exceed .001" per foot (.08 mm per m) in either length or width. Any variations should all be in the same direction, to minimize twist. The maximum allowable twist is considered to be .001" per horizontal foot (.08 mm per horizontal m) measured between any two sections of the base.

Units mounted on soleplates are to be leveled in a similar manner. The plates should be large enough to provide extensions for leveling in both length and width on the finished upper surfaces. Fasten the plates solidly to the blower feet, which are machined flat and parallel to each other, then install and level the blower carefully, using jack screws, shims or wedges for adjusting.

## Installation (Cont'd)

**ALIGNMENT** of the drive shafts when the blower unit and its driver are direct coupled requires careful attention. This precaution will not only help insure satisfactory coupling operation, but will minimize chances for damage to either driving or driven unit from vibration or thrust forces.

In package units with driver and blower mounted on a common baseplate, the two shafts will have been put in approximate alignment at the factory. However, baseplate deflections can occur during shipping and installation. A close coupling alignment should be obtained during leveling, so that only small final adjustments will need to be made after grouting. In a soleplate type installation, the separately mounted driver must be positioned, leveled and aligned as part of the installation procedure. Whether it is on soleplates or on its own base, shims of 1/16" to 1/8" (2-3 mm) thickness placed directly under the driver feet before setting will permit more accurate final alignment. Spacing between the two shaft ends as required by the coupling must also be established. If a motor is being used that has end-play in the shaft, be sure its rotor is located on magnetic center before setting this spacing.

When blower is driven through V-belts, the driver must be mounted on an adjustable base to permit tightening or removing the belts. In this case the driver shaft height is of no concern, but it must be parallel to the blower shaft and level. To position the driver properly, both sheaves need to be mounted on their shafts, and the shaft center distance must be known

The blower sheave, usually the larger one in diameter, must be of the narrow hub type. Install it so that its inner hub face is not more than 1/4" (13 mm) away from the bearing housing end cover. The driver sheave should also be mounted as close to its bearing as possible. Now position the driver so that faces of the two sheaves are accurately in line, with the adjustable base so located as to make 2/3 of its total movement available in the direction away from the blower. This positioning provides minimum belt wear and slip, and allows sufficient adjustment for installation and tightening

of belts. Do not install belts until grouting has set and anchor bolts are tightened.

Blowers intended for driving by V-belts may be provided with an extended drive shaft and an additional outer bearing to handle the side pull of the drive. They may be recognized by the extended housing for the outer bearing. If necessary, these units may also be used for direct coupling to the driver. Blowers intended specifically for direct coupling have no outer bearing, and may be seriously damaged if used for belt drive. Consult your Sales Office for approval before belting these units.

**GROUTING** follows completion of leveling and preliminary alignment. Assuming the foundation has been properly cured, its top surface should first be roughened by chipping to remove glazed areas, and oil or grease should be removed with a strong hot detergent or caustic solution. Grouting serves not only to compensate for surface irregularities in the foundation and machine base but also to provide restraint against shifting. Anchor bolts are used for hold-down only. Therefore, the grout must be adequate thickness under the soleplate or base flange, must flow into anchor bolt sleeves and all interior cavities, and must have minimum shrinkage during the setting period. By virtue of the open frame design, it is recommended that the bedplate be filled with concrete to a level equal to the top of the main channels. Special grouting materials designed to counteract shrinkage are commercially available.

The manufacturer's instructions should be followed in using these materials. Care must be exercised when employing non-shrink additives with cement, as too much can be worse than none. Any gas forming or air-entraining additives should be avoided completely, since they tend to reduce grout strength.

Wait at least 24 hours before tightening anchor bolts or connecting any piping. When jack screws have been used for leveling, make sure the bottom of the leveling screw is treated according to grout manufacturer's instructions so that leveling screw can be backed off. Such points of concentrated loading are likely to wear during machine operation, resulting in loose anchor bolts.

**Table 2A** – Standard Anchor Bolts in Inches

Unit Frame Size	For Soleplates				For Baseplates			
	Bolts		Sleeves		Bolts		Sleeves	
	Dia.	Lgth.	I.D.	Lgth.	Dia.	Lgth.	I.D.	Lgth.
1000	1	24	2	12	3/4	18	2-1/2	13
1200	1	24	2	12	3/4	18	2-1/2	13
1400	1-1/8	36	2-1/4	18	3/4	18	2-1/2	13
1600	1-1/8	36	2-1/4	18	1	24	3	18
1800	1-1/4	36	2-1/4	18	1	24	3	18
2000	1-1/4	36	2-1/4	18	1	24	3	18

**Table 2B** – Standard Anchor Bolts in (cm)

Unit Frame Size	For Soleplates				For Baseplates			
	Bolts		Sleeves		Bolts		Sleeves	
	Dia.	Lgth.	I.D.	Lgth.	Dia.	Lgth.	I.D.	Lgth.
1000	2.4	60	5.0	30	2.0	46	6.5	33
1200	2.4	60	5.0	30	2.0	46	6.5	33
1400	3.0	90	6.5	46	2.0	46	6.5	33
1600	3.0	90	6.5	46	2.4	60	8.0	46
1800	3.0	90	6.5	46	2.4	60	8.0	46
2000	3.0	90	6.5	46	2.4	60	8.0	46

## Installation (Cont'd)

Final bolt tightening should be only enough to hold the machine firmly against the foundation and prevent vibration.

After all anchor bolts are secured, recheck the blower for twist and level. Make corrections to meet the requirements specified under **LEVELING** by shimming under the blower feet. Then rotate the drive shaft by hand to make sure both impellers turn freely at all positions.

When the blower is direct coupled to its driver, final alignment of the two shafts should be accomplished next by adjusting the shims under the driver feet.

This needs to be done with the greatest possible care. Even though a flexible coupling can accept some degree of misalignment, it should not be forced to compensate for careless workmanship. The flexing or sliding member in a coupling will transmit undesirable forces between the two shafts in proportion to the degree of misalignment, thus promoting vibration and unnecessary wear problems.

**MISALIGNMENT** can be of two basic types, offset and angular, but usually it will be a combination of both. For satisfactory coupling operation it is recommended that the following limits be used: maximum deviation in offset alignment not greater than .005" (.13mm) total indicator reading on the coupling hubs; maximum deviation from parallel of the inside coupling faces not greater than .001" (.03 mm) when checked at six points. Where driver is a steam turbine the final alignment should be made at operating temperature in order to allow for shaft

movement resulting from expansion.

A coupling that has been factory installed as part of a pre-assembled package should receive the same final alignment check as outlined above. It will need to be disassembled by removing cover bolts, drawing back the two cover halves, and removing the internal member. In some cases the latter item may have been packed separately for shipment. After necessary adjustments for alignment are completed, lubricate the coupling with grease as specified by its manufacturer and assemble.

A belt-driven installation should require no realignment if all items were correctly positioned and leveled before grouting. Belts may be installed now by adjusting driver position toward the blower sufficiently to permit belts to be laid in their sheave grooves easily. Do not pry or roll them into place. Before doing this, inspect all grooves for burrs, rough spots or oil that might shorten belt life. If equipment is not to be operated immediately, leave the belts slack.

Proper tensioning of the drive for operation should be done in accordance with manufacturer's recommendations, keeping in mind that excessive tension can seriously overload shaft bearings and also lead to premature drive failure. Undertensioning can produce slippage, with consequent loss of blower capacity in addition to belt damage.

Make sure at this point that driver rotation is correct to produce the blower shaft rotation indicated by an

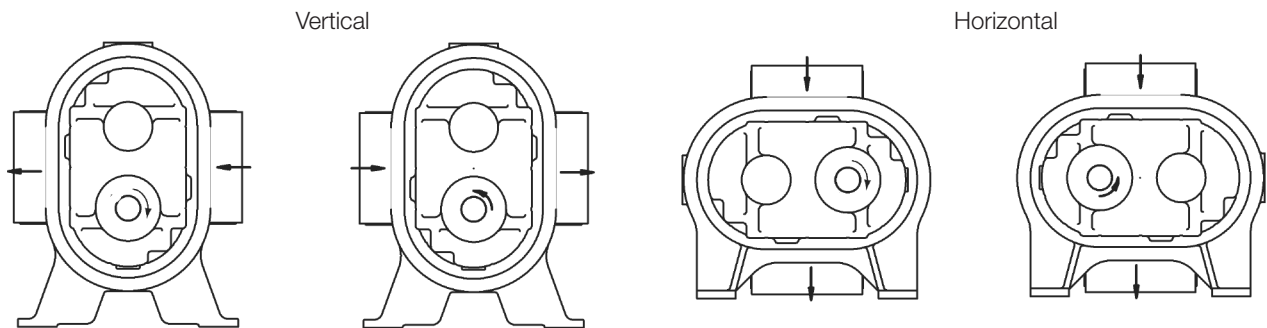

**Figure 4** – Rotation and Discharge, Vertical and Horizontal RAS/RGS Blowers

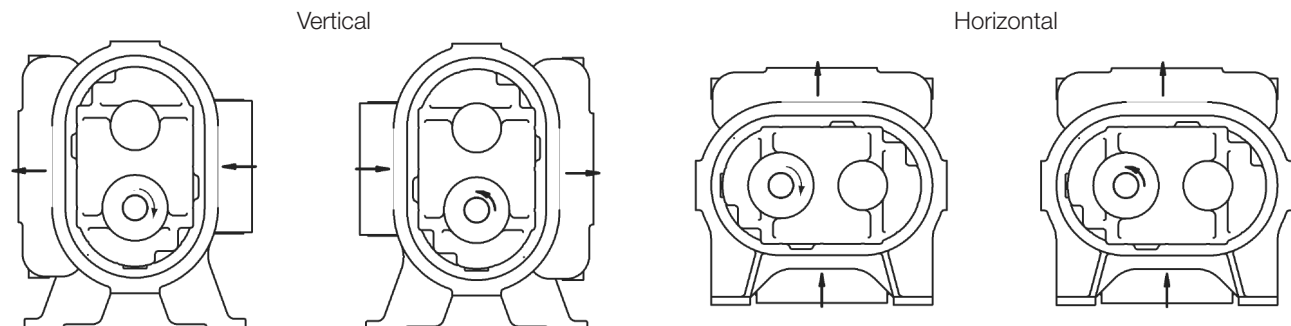

**Figure 5** – Rotation and Discharge, Vertical and Horizontal RAS/RGS Whispair™ Blowers

## Installation (Cont'd)

arrow near the shaft. The Whispair blowers are not reversible, hence drive shaft rotation and discharge flange location are predetermined in manufacturing assembly. Figure 5 page 8 illustrates the assembly options available by specification on original order, to meet piping and drive requirements.

**PIPING must be clean**, and not smaller in size than the blower connections. A good rule-of-thumb is that the air or gas line velocity should not exceed 75 feet (23 m) per second. Where possible, use long radius elbows to insure smooth flow. **Design the piping layout so that no strains are placed on the blower, either from weight or expansion forces. This means providing adequate supports, anchors, and expansion joints or loops.**

Installation of a spool-type rubber expansion joint near the blower inlet connection is recommended. A similar unit with control elements added to minimize piping vibrations may be required near the discharge. Use of **SNUBBERS** or **SILENCERS** in the inlet or discharge piping will be dependent on such factors as blower speed, operating pressure, length and kind of piping, and consideration of sound level requirements in the general surroundings. Whispair blowers operate at generally lower noise levels than conventional lobe-type units. For specific silencer recommendations refer to the nearest Sales Office.

Inlet piping should be completely free of valves or restrictions, but when a shut-off valve cannot be avoided, **make sure** a full size vacuum relief valve is installed near the blower inlet connection. This will protect against an overload caused by accidental valve closing. Even in a gas installation this relief valve protection is essential. Further protection can be provided by installation of a dependable pressure sensitive device with alarm or shutdown action.

During initial operation, install a temporary corrosion-resistant screen at the compressor inlet connection. Screen should be made of 16 mesh (.020" diameter) wire backed with 2 mesh wire cloth. Backing cloth-wire diameter shall be a minimum of 0.063" diameter for 12" pipe, 0.080" diameter for 16" pipe, 0.105" diameter for 20" pipe, and 0.120" diameter for 24" pipe. For 30" and 36" pipe use 1 mesh backing cloth with a minimum of .180" wire diameter for 36" pipe. The table below gives approximate screen pressure drop. A manometer connected to read pressure drop across the screen will indicate when it needs cleaning. Do not allow pressure drop to exceed 55 inches H<sub>2</sub>O. Clean and replace the screen until debris no longer appears. Do not leave the screen installed permanently, as the wire will eventually deteriorate and pieces may go into the blower causing serious damage. (Typically, screens are installed for 1-2 days of operation).

Discharge piping requires a pressure relief valve, and should also include a suitable pressure gauge and unloading valve. The latter permits starting under no-load conditions. The optional back pressure regulator shown in Figure 6 will be required if volume demands vary while blower operates at constant speed. It may blow off to atmosphere if only air is being handled. In a gas installation the regulator will probably need to be located in a by-pass loop back to the blower inlet. However, the volume of gas that may be continuously circulated will be limited by **heat build-up**, which can cause blower damage. Refer such application problems to the nearest Sales Office for recommendations on installation of a by-pass cooler.

In some installations, particularly where two or more blowers discharge into a common header, it is **recommended** that a direct acting or free swinging check valve be provided in each discharge line. These valves, properly installed, protect against damage resulting from reverse rotation caused by back flow through an idle blower.

In making pipe connections to the blower, use special care in lining up the mating flanges. They must contact squarely and accurately, without imposing strain on the blower casing. Any attempt to draw flanges together by force will probably distort the blower and cause internal contacts. Also, the blower should not carry more than the weight of one pipe fitting at each connection. After bolting up the flanges, rotate the drive shaft by hand to check for rubbing contacts caused by strains or dirt.

An oil cooler is standard equipment on all pressure lubricated gas blowers and some air blowers. Therefore, cooling water supply and return piping may be required. To maintain normal oil temperatures during operation, the supply water temperature should not exceed 85° F (29° C).

**Approximate Screen Pressure Drop, Inches H<sub>2</sub>O  
(16 Mesh, .020" Wire Dia.)**

Flow (ACFM)	Pipe Diameter (Inches)						
	12"	16"	20"	24"	30"	36"	42"
2,500	3.0	1.1	0.3	0.3	-	-	-
5,000	12.7	3.9	1.7	0.8	-	-	-
10,000	-	15.5	6.4	3	1.3	-	-
15,000	-	-	14.4	7.2	2.8	1.4	-
20,000	-	-	-	12.7	5.1	2.4	1.4
30,000	-	-	-	-	11.4	5.5	3.0
45,000	-	-	-	-	-	12.3	7.0
60,000	-	-	-	-	-	-	12.5

## Installation (Cont'd)

### V-Belt Drives

#### Recommendations:

- **V-Belt Drive ONLY suitable for Opposite Gear End (OGE) Drive units. V-Belt Drive NOT suitable for Gear End (GE) Drive units.**
- Attempting to belt drive with a motor in excess of 200 HP will make it difficult to size a drive without exceeding the maximum shaft loads. To belt drive over 200 HP generally requires a jackshaft with pillow block bearings connected to the blower by a coupling.
- Use a minimum of 1.4 service factor on the drive horsepower.
- Vertical units must be driven with the motor on the inlet side. Horizontal units must be driven from the drive shaft side.
- Use molded notch belts, power band type where possible.
- The contact arc of the smaller sheave is not to be less than 170°.

Gear Diameter	Dimension "A" (Inches)		Maximum Allowable Shaft Load (Lb./In.)
	With Inboard Bearing	W/O Inboard Bearing	
10"	2.32	4	11,000
12"	2.55	4.09	15,000
14"	2.58	4.55	21,000
16"	N/A	4.97	40,500
18"	N/A	5.68	63,000
20"	N/A	6.05	70,000

Belt Pull (Lbs.) = (275,000 X Motor HP) / (Blower RPM X Sheave Diameter)

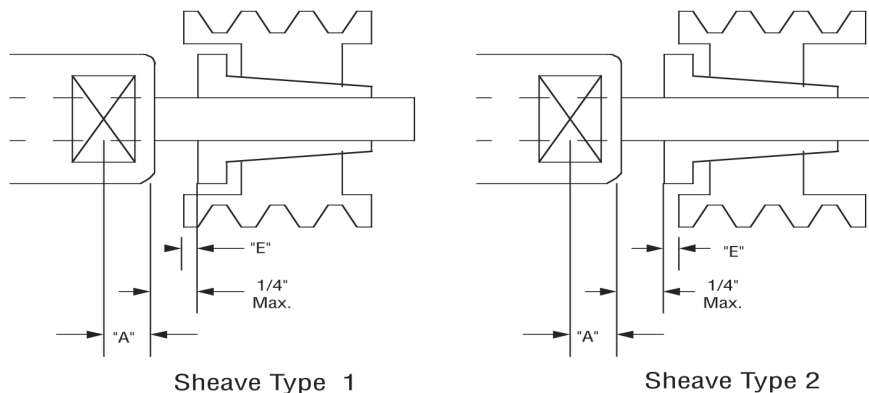

Shaft Load (Lb.-In.) = Belt Pull X (A + 1/4" (+ or - E see below \*) + Sheave width / 2)

\* Subtract "E" if sheave type 1 is used, Add "E" if sheave type 2 is used.

## Installation (Cont'd)

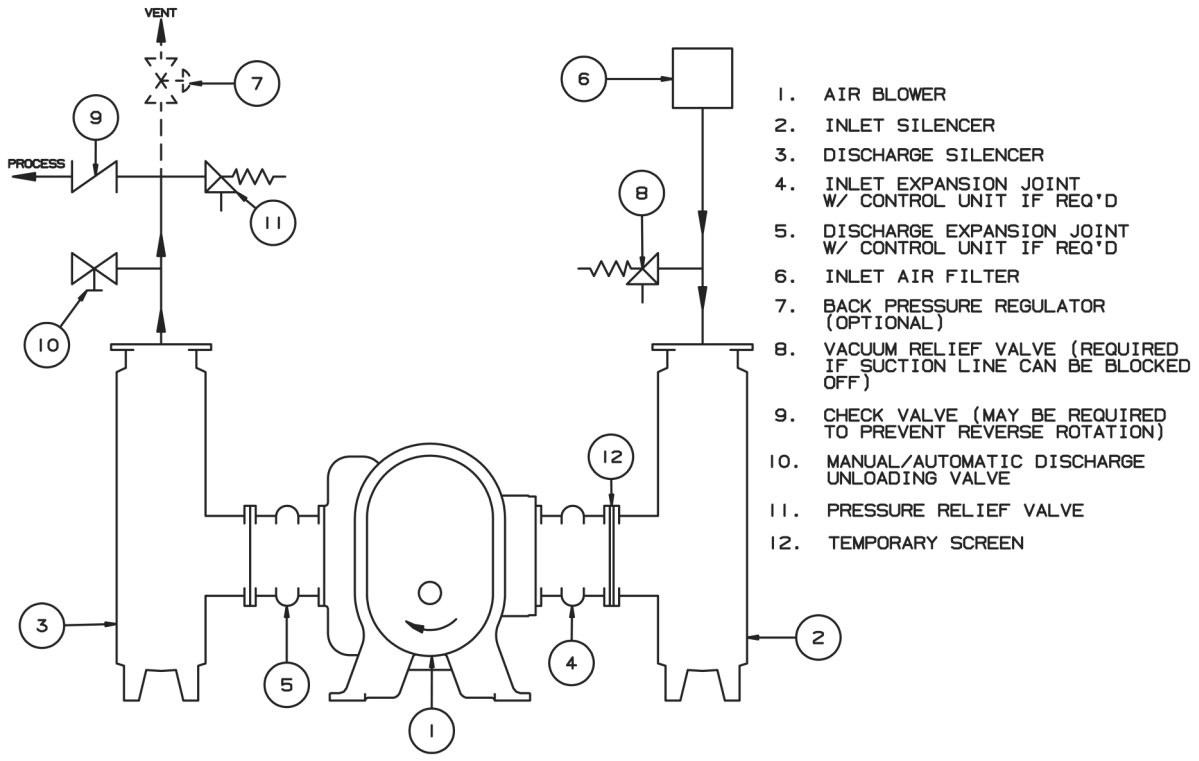

1. AIR BLOWER
2. INLET SILENCER
3. DISCHARGE SILENCER
4. INLET EXPANSION JOINT W/ CONTROL UNIT IF REQ'D
5. DISCHARGE EXPANSION JOINT W/ CONTROL UNIT IF REQ'D
6. INLET AIR FILTER
7. BACK PRESSURE REGULATOR (OPTIONAL)
8. VACUUM RELIEF VALVE (REQUIRED IF SUCTION LINE CAN BE BLOCKED OFF)
9. CHECK VALVE (MAY BE REQUIRED TO PREVENT REVERSE ROTATION)
10. MANUAL/AUTOMATIC DISCHARGE UNLOADING VALVE
11. PRESSURE RELIEF VALVE
12. TEMPORARY SCREEN

RAS-J AIR BLOWER  
PRESSURE SYSTEM SCHEMATIC

Figure 6 – RAS-J Installation with Accessories

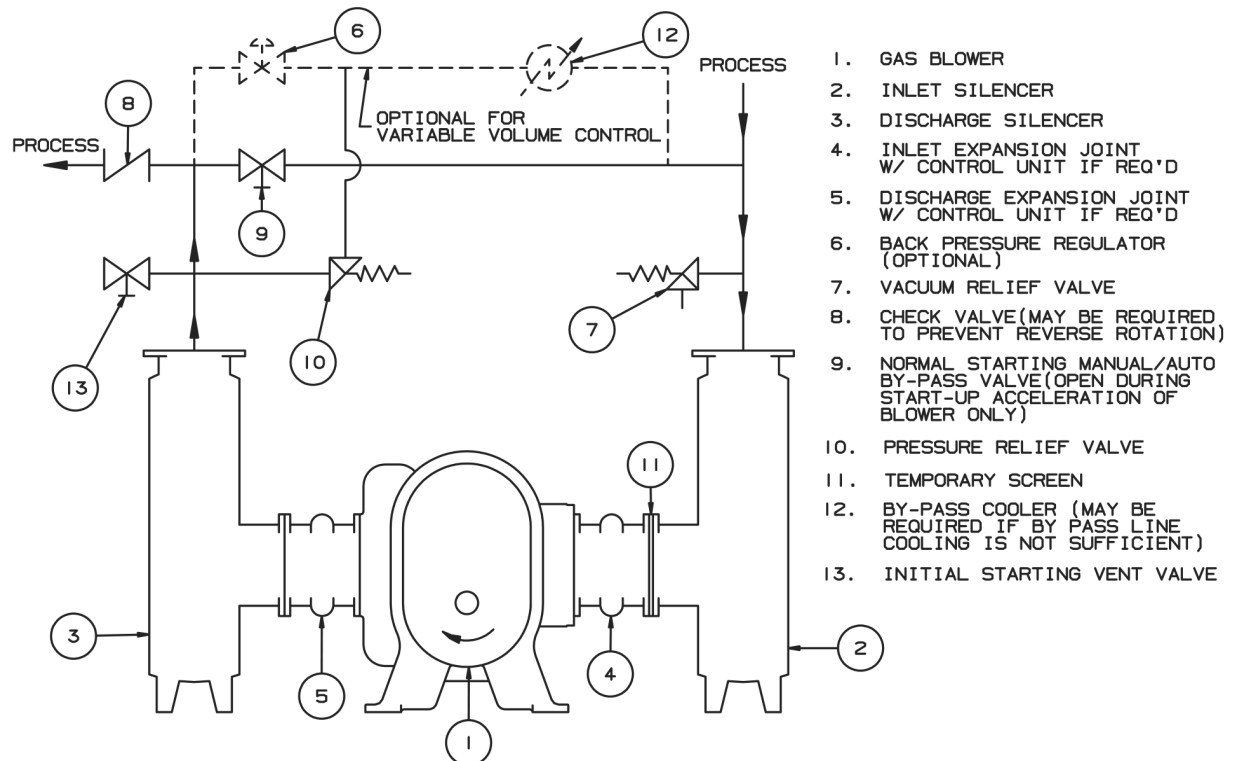

1. GAS BLOWER
2. INLET SILENCER
3. DISCHARGE SILENCER
4. INLET EXPANSION JOINT W/ CONTROL UNIT IF REQ'D
5. DISCHARGE EXPANSION JOINT W/ CONTROL UNIT IF REQ'D
6. BACK PRESSURE REGULATOR (OPTIONAL)
7. VACUUM RELIEF VALVE
8. CHECK VALVE (MAY BE REQUIRED TO PREVENT REVERSE ROTATION)
9. NORMAL STARTING MANUAL/AUTO BY-PASS VALVE (OPEN DURING START-UP ACCELERATION OF BLOWER ONLY)
10. PRESSURE RELIEF VALVE
11. TEMPORARY SCREEN
12. BY-PASS COOLER (MAY BE REQUIRED IF BY PASS LINE COOLING IS NOT SUFFICIENT)
13. INITIAL STARTING VENT VALVE

RGS-J GAS BLOWER  
SYSTEM SCHEMATIC

Figure 6a – RGS-J Installation with Accessories

## Lubrication

The blowers under discussion are pressure lubricated by a self-contained circulating oil system working from a supply sump located in the bottom of the gear housing. Two lines on a bull's-eye type oil level gauge in the sump wall indicate upper and lower supply limits, and filling is accomplished by removing a breather cap.

An oil circulating pump mounted on the gearhouse is driven from one of the blower shafts. Its suction line contains a mesh type strainer located within the sump. Oil distribution lines to gears, bearings and seals are external and of steel tubing with compression fittings. Oil is filtered before delivery to bearing and seals, and is also cooled on gas machines and some air blowers. No provision is made in the oil pump or piping for reversed drive rotation.

Working pressure of the lube system is established by the sizing of drilled internal passages, and by the setting of a relief valve that returns excess oil to the sump. A line-mounted gauge is provided to indicate system pressure, which is normally 12 PSIG (83 kPa).

Figure 7 shows all components of a complete pressure lubrication system, including auxiliary pump.

Timing gears receive oil at their meshing point by direct spray from a passage in the side of the gearbox. All main bearings, and face type shaft seals if used, are supplied through inboard passages in the headplates and bearing carriers. 10" through 14" blowers intended specifically for belt drive normally incorporate an outboard drive shaft bearing mounted in an extended bearing carrier. This bearing is lubricated from a shallow reservoir of oil in the carrier, which is fed through the inboard bearing. Oil delivered to the drive end returns to the main sump at the gear end through a drain line under the blower.

### Instructions for Adjusting Oil Pressure on Pressure Lube

#### Roots Blower

Tools required: large adjustable wrench, short flat-blade screwdriver.

Note: Blower must be running while adjusting oil pressure.

1. Locate pressure gauge and relief valve on side of blower.
2. Remove relief valve protective cover.
3. Loosen locking nut on relief valve stem.
4. Using a screwdriver, rotate the relief valve stem until the pressure gauge reads correct pressure; normal is 10-12 PSI (8 PSI on HVB). Turning the stem clockwise will raise the pressure. Turning the stem counterclockwise will lower the pressure.

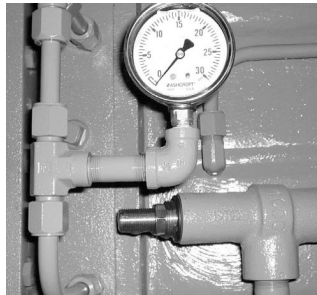

5. Tighten locking nut.
6. Replace relief valve protective cover.

**Note: On RGS units with process pressures higher than 10 PSIG at discharge, consult factory for proper oil pressure settings.**

On a RAS/RAS Whispair air blower, oil is isolated from the air chamber by a double sealing arrangement. Lip

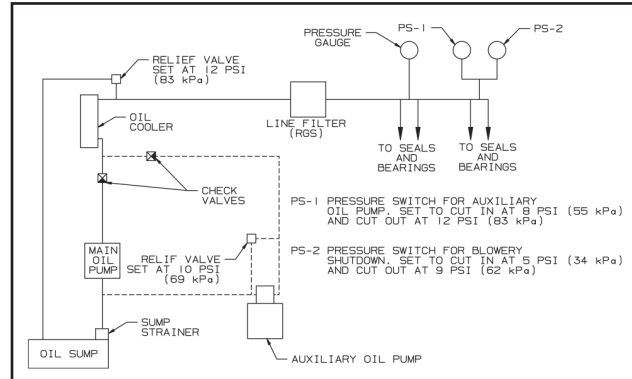

Figure 7 - Lubrication System with Auxiliary Pump

type shaft seals are located directly inboard from the main bearings, followed by labyrinth type seals where shafts pass through the headplates. By venting the chamber between the two sealing points to atmosphere, breathing through the lubrication system is avoided.

On a RGS/RGS Whispair air blower, lip seals are replaced by the rotating mechanical face type shown in Figure 8. While these seals are spring loaded and self-adjusting, their effectiveness as gas seals depends largely on continuous pressure lubrication of the sealing faces. The oil pressure on the shaft side of the seal must be greater than the gas pressure on the opposite side, as noted in Figure 8. If the gas pressure is higher than 8 PSIG (55 kPa), then the normal oiling system pressure of 12 PSIG (83kPa) at the gauge will not provide effective sealing against gas leakage. Refer to factory for correct setting.

The labyrinth type shaft seals in the headplate walls allow free passage of gas into the pockets or chambers around

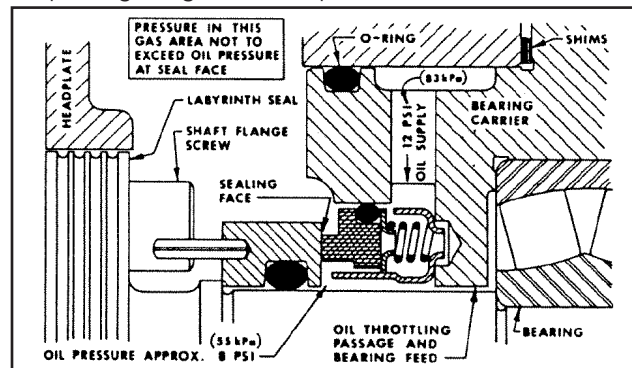

Figure 8 - Face Type Inboard Shaft Seal

## Lubrication (Cont'd)

the gas seals. To prevent leakage of gas outside the blower, drain holes at the bottom of the chambers are sealed with pipe plugs. Since some oil may work through the seals and collect in the bottom of the chambers, these pipe plugs should be removed during periodic shut-downs in order to drain any accumulated oil. There are two plugs to be removed at each end of the blower.

If mechanical face seals are used under conditions where **the static gas pressure at the blower inlet is above atmospheric**, it will be necessary to prevent seal leakage during normal shut-down periods by maintaining continuous oil pressure at the faces of all seals. This can be accomplished by installing an independently driven oil pump, properly connected into the main oil system as indicated in Figure 7.

Operation of the auxiliary pump is under control of a pressure switch in the blower oil distribution piping, normally set to cut in at 8 PSIG (55 kPa) and cut out at 12 PSIG (83 kPa). A pressure relief valve set at 10 PSIG (69kPa) should be installed in a bypass around the pump. The auxiliary pump must run continuously while gas pressure remains in the blower. A second pressure switch is furnished as part of the auxiliary pump package, to protect the blower against low oil pressure during normal operation. Set to operate at 5 PSIG (34kPa) and 9 PSIG (62 kPa), one contact is used to stop the blower motor at the low pressure setting. Another contact may be used to operate an alarm at the same time.

For RGS units with discharge pressure greater than 10 PSIG consult factory for proper setting.

Lubricating oil viscosity should be selected from Table 3 for the existing ambient temperature range. Fill the blower oil sump through the breather pipe to the upper gauge line before starting operation, and recheck the level soon after the first startup. If it falls below the lower gauge line, add sufficient oil to bring it back to the upper line. During the first week of normal blower operation the oil level should be checked daily. Thereafter a weekly check probably will be sufficient. Do not permit the level to drop below the lower gauge line, nor go above the upper line. Use only non-detergent premium grade lubricant with foam, oxidation, and rust inhibitors. The use of Roots synthetic oil from Roots is highly recommended.

Oil should be changed after the first 100 hours of

**Table 3** - Recommended Lubricating Oils

Ambient Temperature	ISO Viscosity Range
32° to 120°F (0° 49°C)	200
Below 32°F (18°C)	100
<b>All RGS - Use ISO-VG-100</b>	

**Table 4** - Oil Sump Capacities

Frame Series	Approx. Capacity in Gallons (Liters)	
	Vertical	Horizontal
1000	5-1/4 (20)	7-1/2 (28)
1200	7-3/4 (29)	10-3/4 (41)
1400	10-3/4 (41)	14-1/2 (55)
1600	15 (57)	20 (76)
1800	19-1/2 (74)	25-1/4 (96)
2000	23 (87)	30-3/4 (116)

operation. After the initial oil change, an oil change frequency of 2,000 hours would be considered normal. More frequent oil changes may be necessary if the blower is in a very dusty or contaminated environment. The use of Roots synthetic oil from Roots can extend life up to eight times that of mineral oil. Testing of oil should be used to determine change intervals. It may be advisable to check oil condition each time the weekly level check is made, until a regular change period can be determined. At each oil change, remove and thoroughly clean the strainer screen in the oil sump.

On type RGS/RGS Whispair units from Roots also replace the cartridge in each oil line filter at oil change periods in order to protect the mechanical shaft seal faces. These seals may leak a certain amount of oil in normal operation, which will collect in a chamber in each headplate under the lower shaft (under both shafts in a horizontal unit). The oil levels in these chambers should not be allowed to reach the labyrinth shaft seal openings.

Therefore, when an RGS/RGS Whispair blower is shut down, remove the pipe plugs and drain any accumulated oil from these chambers. Experience will indicate the frequency of draining required. Be sure to shut off the gas supply to the blower before removing the drain plugs.

Lip seal oil leakage on RASIRAS Whispair blower from Roots: Some oil seal leakage will occur at the drive shaft seal and the headplate seals since an oil film under the lip is required for proper operation. Periodically, the leaked oil should be wiped off from the blower as well as base plate surfaces, since even a small amount of leaked oil spreads over a large area making the leakage look worse than actual.

On a unit with cooler, the maximum oil temperature to bearings and gears should not be higher than 120° F (49° C). Oil returning to the sump will then normally be at about 160° F (71° C) or less. These conditions can be maintained only if the cooler tube bundle is not allowed to become fouled with deposits from the cooling water, and if the water temperature is less than 85° F (29° C). Rate of water flow required can be expected to be between 3 to 10 GPM.



## Operation

Before starting the blower under power for the first time, recheck the installation thoroughly to reduce the likelihood of troubles. Use the following procedure check list as a guide, but also consider any other special conditions in the installation.

1. **Be certain** no bolts, rags or dirt have been left in the blower air chamber.
2. **Be certain** that inlet piping is free of debris. Use of the temporary protective screen at the blower inlet as described under **INSTALLATION** is strongly recommended during early operation. If an outdoor intake without filter is used, be sure the opening is clean and protected by a strong screen.
3. **Check** blower leveling, drive alignment, belt tension and tightness of all mounting bolts if installation is not recent.
4. Turn drive shaft over by hand to make sure impellers will rotate without bumping or rubbing at any point.
5. **Check** lubrication system. Oil level in gearhouse sump should be at or near the upper gauge line. **Make sure** filters in bearing lines contain filtering cartridges. If an oil cooler is in the system, be sure water supply and return lines are connected and operating.
6. If driver is an electric motor, make sure it is also properly lubricated. Check that power is available, and that all electrical overload devices are installed and in operating condition.
7. If unit is an **air blower**: Open the manual unloading valve in the discharge line and make sure that any blocking valve in the inlet piping is open.
8. If unit is a **gas blower**: Vent the discharge line by opening the initial starting blow-off valve, while keeping the normal starting by-pass valve closed. See Figure 6. Inlet piping should be open to atmosphere (not connected to gas supply) during start-up and unit has been tested.
9. Bump blower a few revolutions with driver to check direction of rotation and to see that both units coast freely to a stop.
10. Start blower. Let it accelerate to full speed, then shut off. Listen for any knocking sounds, both with power on and also as it slows down. Observe oil pressure to determine whether oil pump is primed and functioning properly. Pressure should approach 10 to 12 PSI (69 to 83 kPa) after only a few seconds.
11. If no problems have appeared, restart unit and operate for 5 to 10 minutes under no-load conditions as in paragraph 7 or 8. Check the cylinder surfaces all over by feeling to locate any hot spots indicating impeller rubs. Continue to listen for noises and watch for changes in vibration. If all conditions are acceptable, proceed as follows:
  12. For an **air blower**: Continue operating, but gradually close the discharge unloading valve. A good pressure gauge or manometer should be connected into the discharge line. Observe the pressure increase as valve is closed, and do not permit it to exceed the rating of the unit as specified under **LIMITATIONS**.
  13. For a **gas blower**: Stop the unit and connect the inlet piping to the gas supply. Close and lock the starting vent valve, or remove it and blank off the opening. Open the normal starting bypass valve and restart the unit. After it reaches full speed, start closing the bypass valve fairly rapidly. Observe the discharge pressure gauge or manometer as the valve is closed, and do not allow the pressure to exceed the rating of the unit as specified under **LIMITATIONS**. (See following **NOTE**).
  14. All conditions being satisfactory to this point, continue the run for about one hour under normal operating conditions. It is recommended pressure or vacuum measurements be used on both inlet and discharge to permit determination of pressure rise across the unit. Also use thermometers to determine the temperature rise. Both figures should stay within the specified limits. Continue checking for noises and hot spots, and take periodic reading of oil system pressure. If trouble shows up, refer to the **TROUBLE SHOOTING CHECKLIST** for suggestions.

**NOTE** - When starting a gas blower under normal operating conditions, open bypass valve only until full speed is reached. Close it rapidly then so that blower temperature will not be increased by the circulating gas. See discussion of discharge piping under **INSTALLATION** relative to use of a regulated continuous **gas bypass with cooler**.

The unit should now be ready for continuous duty under full load. During the first several days, make periodic checks to be sure that all conditions remain reasonably steady and within limits. These checks may be especially important if the unit is part of a process system where conditions may vary. At the first opportunity, stop the blower and clean or remove the protective inlet screen. At the same time, verify leveling, coupling alignment or belt tension, and anchor bolt tightness.

Should operation of an air blower prove that its capacity is a little too high for actual requirements, a small excess may be blown off through the manual unloading or vent valve. **Never rely on the pressure relief valve as an automatic vent.** Such use may cause the discharge pressure to become excessive, and can also result in failure of the valve itself. If blower capacity is low, refer to **TROUBLE SHOOTING CHECKLIST**

## Troubleshooting Checklist

Trouble	Item	Possible Cause	Remedy
No Flow	1	Speed too low	Check by tachometer and compare with speed on Roots's Roots Order Acknowledgment Compare actual rotation with Figure 4 or 5. Change driver if wrong. Check piping, screen, valves, silencer, to assure open flow path.
	2	Wrong Rotation	
	3	Obstruction in piping	
Low Capacity	4	Speed too low	See item 1. If belt drive, check for slippage and readjust tension.
	5	Excessive pressure rise	Check inlet vacuum and discharge pressure, and compare these figures with specified operating conditions on order.
	6		
	7	Obstruction in piping Excessive slip	See item 3. Check inside of casing for worn or eroded surfaces causing excessive clearances
Excessive Power	8	Speed too high	Check speed and compare with Roots's Roots Order Acknowledgement.
	9	Excessive pressure rise	See item 5.
	10	Impellers rubbing	Inspect outside of cylinder for high temperature areas, then check for impeller contact at these points. Look for excessive scale build-up. Correct blower mounting, drive alignment.
Overheating of Bearings of Gears	11	Inadequate lubrication	Check oil pressure, oil sump level and condition of oil.
	12	Excessive lubrication	Check oil pressure, oil sump level and condition of oil.
	13	Excessive pressure rise	See item 5.
	14	Coupling misalignment	Check carefully. Realign if questionable.
	15	Excessive belt tension	Readjust for correct tension.
Vibration	16	Misalignment	See item 14.
	17	Impellers rubbing	See item 10.
	18	Worn bearings/gears	Check gear backlash and condition of bearings, and replace as indicated.
	19	Unbalanced or rubbing impellers	Scale or process material may build up on casing and impellers, or inside impellers. Remove build-up to restore original clearances and impeller balance.
	20	Driver or blower loose	Tighten mounting bolts securely.
	21	Piping resonances	Determine whether standing wave pressure pulsations are present in the piping. Refer to Sales Office.
Oil in Process	22		See discussion of sealing under LUBRICATION.

## Safety Precautions

For equipment covered specifically or indirectly in this instruction book, it is important that all personnel observe safety precautions to minimize the chances of injury. Among many considerations, the following should particularly be noted:

- Blower casing and associated piping or accessories may become hot enough to cause major skin burns on contact.
- Internal and external rotating parts of the blower and driving equipment can produce serious physical injuries. Do not reach into any openings in the blower while it is operating, or while subject to accidental starting. Cover external moving parts with adequate guards.
- Disconnect power before doing any work, and avoid by-passing or rendering inoperative any safety or protective devices.
- If blower is operated with piping disconnected, place a strong coarse screen over the inlet and avoid standing in the inlet or discharge air stream.
- Stay clear of the blast from pressure relief valves and the suction area of vacuum relief valves.
- Avoid extended exposure in close proximity to machinery with high intensity noise levels.
- Use proper care and good procedures in handling, lifting, installing, operating and maintaining the equipment.
- Casing pressure must not exceed 25 PSI (172 kPa) gauge. Do not pressurize vented cavities from an external source, nor restrict the vents.
- Do not use air blowers on explosive or hazardous gases.
- Other potential hazards to safety may also be associated with operation of this equipment. All personnel working in or passing through the area should be warned by signs and trained to exercise adequate general safety precautions.

## Preventive Maintenance

### 1. Daily

- A. Record the following:
  - 1) Lube oil pressure (if applicable).
  - 2) Lube oil temperature (if applicable).
  - 3) Blower inlet temperature.
  - 4) Blower inlet pressure.
  - 5) Blower discharge temperature.
  - 6) Blower discharge pressure or differential pressure.
  - 7) Motor amperage.
  - 8) Motor voltage, if available.
  - 9) Motor stator temperature, if available.
  - 10) Motor bearing temperature, if available.
- B. Observe any abnormalities, i.e. burned paint, unusual noises, vibration, strange odors, oil leaks, etc.
- C. Review log sheets to determine if there are any changes from previous readings (it is very important to look for any changes or trends which might indicate pending problems).
- D. Check oil levels.
- E. Record hour meter readings.

### 2. Monthly

- A. Record bearing housing vibration levels at each Use velocity (in./sec.) measurements and note any changes from previous readings. Take a complete vibration signature (amplitude versus frequency) if any trends are noted. (It may be helpful to keep a chart on monthly readings.)

### 3. Quarterly

- A. Sample lube oil or change.
- B. Change oil if the following values are exceeded:
  - 1) Water 100 PPM maximum.
  - 2) Metals 200 PPM maximum.
  - 3) Acid 5.0 to 7.5 Mg/KOH/g maximum.
- C. Increase frequency of sampling if any of the above values show about 20 to 25 percent increase over the last sample.
- D. Flush all oil reservoirs before filling with clean oil.

### 4. Annually

- A. Remove an inlet expansion joint, inspect impellers, measure impeller clearances and note wear patterns.
  - B. Check coupling alignment, inspect coupling for wear, and repack with fresh grease.
  - C. Inspect oil cooler tubes, as applicable.
  - D. Check all protective switches for proper setpoints and operation.
  - E. Check V-belt drive condition and tension.
5. A Preventative Maintenance Schedule should be established for driver(s) and all accessories in accordance with the applicable manufacturer's recommendation.

## Rotary Lobe Blower Vibrations

The general vibration severity charts derived from Rathbone vibration severity charts provide guidelines for machines basically having mass unbalance (turbomachinery, electric motors, etc.) The German specification VDI 2056 - Criteria for Assessing Mechanical Vibrations of Machines - provides vibration guide lines for machines with rotating masses (turbomachinery) and machines having mass effects which cannot be balanced (reciprocating machines), but does not specifically address rotary lobe blowers (also known as Roots blowers from Roots) with inherent fluctuating dynamic bearing loads and torques.

API Standard 619, Rotary Type Positive Displacement Compressors for General Refinery Services, limits the vibration level to 0.1 in/sec peak, which is quite ambitious.

Based on experience, practical acceptable vibration levels lie somewhere between API 619 requirement and VDI 2056 allowance for group D reciprocating machines.

### Elements Generating Vibrations in Rotary Lobe Blower:

1. Inherent rotary lobe blower characteristics can lead to vibrations:
  - a. Impacting bearing loads excite component/system natural frequencies.
  - b. Pressure pulsations set off vibrations at four times the running speed (RPM). Pulse maximum limits (PSI peak to peak) of rotary blowers are as follows:
    - Blower inlet: 5% of absolute pressure
    - Blower discharge: 8% of absolute pressure
    - Blower jet inlet (DVJ): 8% of absolute pressure

Example: Blower with absolute inlet (14.7 PSIA) and 11 PSIG discharge (25.7 PSIA), would have maximum pressure pulse of  $.05 \times 14.7 = .74$  PSI for inlet &  $.08 \times 25.7 = 2.06$  PSI for discharge.

During blower commissioning, measurement of system pressure pulsation levels and blower vibrations are recommended to validate the system design. Pressure measurement shall be a dynamic pressure probe located approximately 1 pipe diameter from blower flange. Also pressure probe should be minimum of 2 pipe diameters away from significant transition such as pipe elbow or process valve.

2. Rotary lobe blowers use very close clearances between the impellers and the housing. The impeller contact will setup vibrations as follows:
  - a. Impeller to impeller frontal lobe contact - if contact is between only one set of lobes, the vibration frequency will be 1XRPM; if both sets of lobes contact, the vibration frequency will be 2X RPM.
  - b. Impeller to cylinder contact - the vibration

frequency will depend on the number of impeller tips contacting the cylinder, which could range from one to four times the RPM.

- c. Impeller to head plate contact - the vibration frequency will be erratic and unsteady.
3. Damaged gears will generate vibrations at mesh frequency, number of teeth times RPM.
4. Damaged bearings will generate vibrations at ball pass frequency, fundamental train frequency and ball spin frequency.
5. Rotor unbalance and bent shaft will generate vibrations at 1XRPM.
6. Blower/driver coupling misalignment will generate vibrations at 1XRPM and 2XRPM.
7. Acoustic resonance in the blower inlet/discharge piping will generate vibrations at 4XRPM.
8. Operation of rotary lobe blower at or near system torsionals may cause impeller lobe contact and increases vibrations.
9. External piping if not properly isolated will transmit vibrations into the blower.
10. Foundation design and method of mounting has considerable effect on blower vibrations.

### Vibration Criteria:

1. Units of measurement: Rotary lobe blower vibrations are measured in inches/sec. Measurements of spike energy are not recommended for judging blower condition because the rotary lobe blower has inherent impacting bearing loads.
2. Measurement location: Vibrations should be measured at the bearing locations on the housing.

The following table provides an appropriate assessment guideline for rotary lobe blowers rigidly mounted on the stiff foundations.

Unfiltered Vibrations (in/sec peak)	Assessment
<0.45	Very Good
>0.45 to 0.62	Good
>0.62 thru 1.0	Satisfactory
>1.0	Review Required

If the blower is operating at "review required" levels then the installation must be fully evaluated to determine the source or cause of vibration and the cause shall be corrected.

In general, blower vibration levels should be monitored on a regular basis and the vibration trend observed for progressive or sudden change in level. If such a

change occurs, the cause should be determined through spectral analysis.

The blower vibrations will be transmitted into the motor, speed reducer etc. and more so if they are mounted on the common blower baseplate. Allowable vibration levels into these accessories should be obtained from the vendors.

## RGS WHISPAIR for Steam Service

Except as noted below, instructions for RGS WHISPAIR blowers from Roots applies.

### Limitations

Most blowers for steam service are supplied with involute (RP-71) impellers. The table of maximum operating conditions for these impellers as shown in the IO&M applies except for the speed. The blower may be run at the speeds shown only if the impellers are hardened or the blower is being run on dry steam with no water injection. If the steam is wet, or if water is being injected, the speed is limited to 4200 Ft/Min.

Gear Speed.

$$[\text{RPM} = 4200 / (.262 \times \text{Gear Dia.})]$$

Some blowers for steam service are supplied with Segment Waist (RP-36) impellers. Maximum operating conditions for blowers supplied with this type impeller are the same as those shown for RP-71 impellers except the temperature rises on some sizes as follows:

**Table 5** - Segment Waist (RP-36) Maximum Temperature Rise

Frame Size	Temperature Rise		Frame Size	Temperature Rise	
	°F	°C		°F	°C
1009	240	133	1625	230	128
1012	240	133	1627	230	128
1212	235	131	1821	225	125
1216	235	131	1824	225	125
1414	230	128	1827	225	125
1418	230	128	2022	215	119
1616	230	128	2026	215	119
1620	230	128			

The same speed restrictions apply to Segment Waist impellers as to Involute.

### Maximum Temperature Rise Correction

In most steam services, the blower inlet temperature is much higher than the ambient temperature. The temperature rise values listed in the tables must be corrected if this is the case. The maximum temperature rise as shown on the tables must be reduced by 2/3 the

difference between the actual inlet temperature and the ambient temperature, and the average inlet to discharge temperature must not exceed 250°F. For example:

The maximum temperature rise of a 1009 RGS WHISPAIR is shown as 240°F. With a steam inlet temperature of 212°F and an ambient temperature of 70°F the maximum temperature rise is limited as follows:

$$\text{Max. Temp. Rise} = 240 - 2/3 (212 - 70) = 145^\circ\text{F}$$

$$\text{Discharge temperature will then be} = 145 + 212 = 357$$

$$\text{Average temperature} = (212 + 357) / 2 = 284.5^\circ\text{F}$$

This exceeds the 250°F rule, so the temperature rise must be limited to:

$$\text{Max. Temp. Rise} = 2 \times (250 - 212) = 76^\circ\text{F}$$

### Water Injection

De-mineralized water may be injected, with proper precautions, at the suction of the blower to reduce the temperature rise. The amount of water injected is normally enough to keep the steam at discharge pressure saturated. The actual amount required will depend on the system and the efficiency of evaporation, but the approximate amount can be calculated :

$$\text{GPM} = \text{HP} \times 42.44 / (1000 \times 8.35) \text{ Where:}$$

GPM = Gallons Per Minute of Water

HP = Horsepower to the Blower

42.44 = Conversion HP to BTU/Min.

1000 = BTU per Pound of Water

8.35 = Pounds of Water per Gallon

This amount should be doubled to start, and reduced as needed.

### Installation

Bellows type stainless steel expansion joints should be used on the inlet and discharge connections of the blower. Both inlet and discharge pipes must be anchored to prevent any piping movement which could cause over extension or compression of the expansion joints.

If water is injected into the inlet of the blower, the inlet and discharge silencers and headplate vent cavities must be continuously drained as condensed water will build up in these areas. The headplates are supplied with two pipe tapped and plugged holes on each headplate. These cavities can be piped to drain by hand at regular intervals as the system characteristics demand, or piped to a trap or barometric seal leg. (See Figure 9) If the water is allowed to build up in the headplate vent cavity, serious damage to the blower will result.

Note that there may be oil present in the drainage from

## RGS WHISPAIR for Steam Service (Cont'd)

the headplate vent cavities. This should be disposed of properly.

A typical steam blower piping setup showing recommended gauges and switches is shown in Figure 10.

### Startup and Operation

Before the first startup of the blower, follow the instructions in the IO&M with these added measures: (Refer to Figure 10)

1. Vent the discharge line by opening the startup vent valve (9), while keeping the bypass valve (7) closed. The inlet piping should be opened to atmosphere (not connected to the steam supply) during startup and until the blower is tested. Open the cylinder drain valve (14), remove all water and close it.
2. If an auxiliary oil pump is supplied, turn it on and set the auxiliary relief valve at 10 PSIG.

After the initial run of the blower:

1. Stop the blower and connect the inlet piping to the steam supply. Close and lock the starting vent valve (9), or remove it, and blank off the opening. Open the normal starting bypass valve (7).
2. In a vapor re-compression system, the evaporator, compressor (blower), piping and condenser equipment must be purged of air (non-condensables) before startup of the main compressor. In order to assure this fact, the system requires steam to be supplied in the evaporator area so it flows through the compressor and piping to an air/steam vent on the far end of the condenser. An inlet thermometer and a casing temperature switch are recommended to partially assure that the system is purged prior to startup. The casing temperature should be within 10°F of the purge

steam saturation temperature.

3. Restart the blower (start the inlet water spray if applicable). After the blower reaches full speed, start closing the bypass valve fairly rapidly.
4. Observe the discharge pressure gauge as the bypass valve is closed, and do not allow the pressure or temperature to exceed the rating of the blower as specified under Limitations.

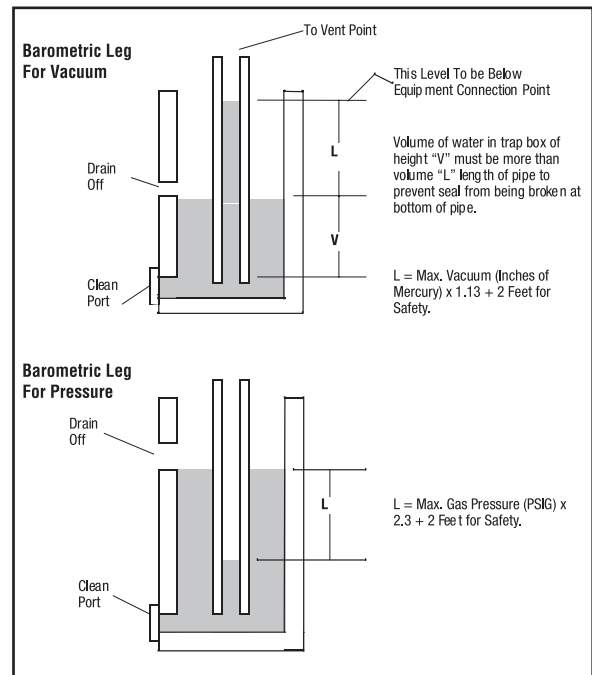

Figure 9 - Barometric Seal Leg

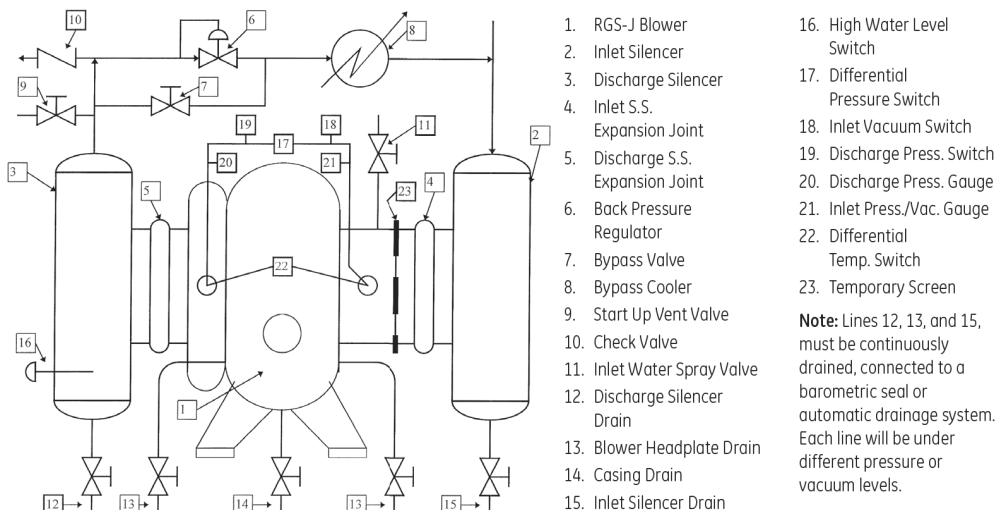

Figure 10 - Steam Blower Installation

## RGS 10” - 20” Gear Diameter Blowers for High Vacuum Booster (HVB) Service

NOTE: These instructions are applicable to those type RGS pumps supplied for HVB service. It covers only those points where a booster differs from standard series RGS gas pumps. All other information, installation, and service data should be obtained from referenced sections while considering exceptions below.

### INSTALLATION

Power required by HVB is generally smaller than required in normal applications. Therefore, the drive shaft arrangement shown for coupling drive is sometimes furnished on V-belt-driven 10 through 14 inch HVB pumps. Reduction in belt load makes extra bearing support for V-belt drive unnecessary.

Vacuum system piping must be vacuum-tight throughout. Leaks will seriously affect and limit performance of HVB and complete vacuum system.

### LUBRICATION

Use rust, oxidation and foam inhibited non-detergent oil with low vapor pressure characteristics (0.1 micron of mercury or less at 180°F and 1.8 micron of mercury or less at 250°F). Viscosity range should be 450-600 SUS at 100°F or ISO VG 100 oil. Normal oil pressure is 8 PSIG (55kPa).

### OPERATION

Initial starting procedures outlined under OPERATION in Instruction Manual must be followed generally. Steps 11 and 12 in referenced manual are not applicable to HVB and the following should be used:

The final operating checks are made with the HVB connected to vacuum system, which should be set for normal operating conditions. Start the system fore-pump and run it alone until inlet pressure of HVB is about 15 mm Hg absolute (15.0 Torr) (2.0 kPa).

During this pump down, HVB may windmill. Now start HVB manually or with vacuum pressure switch at HVB inlet. NOTE: HVB will OVERHEAT if operated at 15 mm Hg absolute inlet pressure longer than 5 minutes.

Providing a suitable pressure gauge at HVB inlet allows system check for tightness during initial pump-down period. Under normal conditions, systems reach anticipated pressure within 15 to 30 minutes. If it fails to do this, the cause may be continued out-gassing of various surfaces within the system, leaks, or both. Out-gassing sometimes requires 24 hours, but depends on system size. It is advisable to first check for leaks in the piping, joints, seals, etc. This may be done by stopping pumps, isolating system with a vacuum tight valve, and observing pressure rise rate of system.

### MAINTENANCE

Periodic inspections include check of liquid level gauge located on side of each headplate. Extended periods of operation allow seal oil to accumulate in chambers behind these gauges. Should gauges show oil, chambers should be drained. Caution: Do not drain main oil supply sumps by mistake.

**IMPELLER CLEARANCES will always be segment waist**



## Maintenance/Replacements

A good program of inspection and maintenance servicing, if followed consistently, is the most reliable means of preventing costly repairs to a blower. A simple record of procedures and dates will help maintain this work on a regular schedule. Basic requirements are lubrication and cleaning, along with periodic checking for increased vibration and hot spots on the cylinder. Inlet and discharge pressures and temperatures should be observed frequently, to minimize the chances for trouble resulting from blower ratings being exceeded. Above all, **the unit must be operated within its specifications.**

In a blower properly installed and operated, there is no moving contact between the two impellers, or between the impellers and cylinder or headplates. Wear is then confined to the timing gears, the bearings which support and locate the shafts, and shaft seals, and the oil pump. All are lubricated, and wear should be normal if they are always supplied with clean, high grade lubricating oil. Shaft seals, whether lip type or rotating mechanical type, are subject to deterioration as well as wear. They may require replacement at varying periods. O-rings should be replaced at each disassembly, and oil line filter cartridges are routine replacement items.

If trouble should occur during operation, and its cause cannot be readily determined, consult the **TROUBLE SHOOTING LIST**. Repairs not covered in this manual are considered beyond the scope of maintenance, and should be referred to Roots Roots. **Warranty failures** should not be repaired at all, unless specific approval has been obtained through a Sales Office before starting the work. Unauthorized disassembly within the warranty period may void the warranty.

Where repairs involve parts replacement, it is recommended that Factory Parts be used to insure fit and suitability. Delay in making such repairs can be reduced by having spare parts on hand.

When ordering parts, please furnish all information from the blower nameplate.

## Troubleshooting and Repairs

### Repair Kit Information For RAS/RGS Lube Blowers 10" - 20"

Ref.	Qty.	Part Description
17	1	Shim Set
18	2	Gasket
19	1	Gasket
20	4	O Ring
23	1	Seal, Drive Shaft
24	2	Locknut, Bearing
25	2	Lockwasher, Bearing - Except 10"
27	4	Seal, Headplate
31	Varies	Bearings
42	1 set	Capscrews
80	2	Bearings

**When ordering spare parts contact:**

Roots Roots  
900 West Mount Street  
Connersville, IN 47331-1675

Email: [Connersville.Customercare@Roots.com](mailto:Connersville.Customercare@Roots.com)

Phone: 765-827-9200

## Parts List

**Table 10** - Parts Identification List for Figures 21-25

Item Number	Quantity Used	Identification
1	2	Headplate
2	1	Cylinder
3	1	Gearbox
4	1	Cover Plate - Gearbox
5	1	End Cover - Main
6	4	Bearing Carrier
7	2	Impeller
8	2	Bearing Clamp Plate, Drive End
9	2	Timing Gear
10	2	Gear Locking Assembly
11	1	Relief Valve - Oiling System
12	2	Stub Shaft - Gear End
13	1	Stub Shaft - Driving
14	1	Stub Shaft - Driven
16	1	Key - Drive Sheave or Coupling
17	4 halves	Shims - Bearing Carrier, Drive End
18	2	Gasket - End Cover & Gearbox
19	1	Gasket - Gearbox Cover Plate
20	4	"O" Ring - Brg. Car. (See Data Table)
21	8	Lockwasher - Brg. Clamp Plate & End Cover
22	8	Capscrew - Brg. Clamp Plate & End Cover
23	1	Shaft Seal - Outboard (See Data Table)
24	2	Bearing Locknut
25	2	Bearing Lockwasher
26	16	Lockwasher - Brg. Carrier (See 49)
27	4	Shaft Seal - Inboard (See Data Table)
28	1	Breather Cap - Drive End
29	2	Eyebolt
30	Varies	Capscrew - Headplate & Cylinder
31	4	Bearing - Main (See Data Table)
32	3	Soc. Hd. Screw - Oil Pump Coupling
33	1	Set Screw - Oil Pump Coupling
34	2	Nameplate
35	6	Drive Screw - Name Plate & Rotation Arrow
36	12	Dowel Pin - Flange Locating
37	1	Breather Cap - Oil Sump
38	1	Oil Pump (See Data Table)
39	1	Nipple - Oil Sump Breather
40	4	Cap Screw - Oil Pump Mounting
41	1	Coupling - Oil Pump Drive

Item Number	Quantity Used	Identification
42	Varies	Soc. Hd. Cap Screw - Stub Shaft
43	Varies	Taper Pin - Stub Shaft, Gear End
46	Varies	Capscrew - Gearbox Cover Plate
49	16	Cap Screw - Brg. Carrier (See 26)
51	1	Oil Strainer - Sump (See Data Table)
52	1	Adapter - Oil Strainer
53	4	Cap Screw - Strainer Mounting
54	4	Cap Screw - Oil Gauge Mounting
55	1	Oil Level Gauge
56	1	Rotation Arrow
57	1 or 2	Oil Filter (See Data Table)
58	1	End Cover - Drive Shaft
59	1	"O" Ring - Bearing Carrier, Outboard
60	1	Bearing - Inboard (See Data Table)
61	1	"O" Ring - End Cover (See Data Table)
62	1	Spacer Sleeve - Outboard Bearing
63	1	Bearing Carrier - Drive Shaft, Outboard
64	2	Spring Pin - End Cover (10-14" Only)
66	1	Vent - End Cover
67	1	Plug - Oil Drain
68	1	Pipe Plug (12-20" Only)
69	4	Pipe Plug
70	11	Pipe Plug
72	4	Set Screw
74	1	Rotation Arrow
77	2	Spacer Sleeve
79	1	Adapter - Oil Pump, Frames 1000, 1800 & 2000
87	1	Sight Plug, GE
100	4	Dowel Pin (10-14" Only)
101	2	Bearing Locknut (10" Only)
105	1	Shaft, OGE Drive (16-20" Only)
128	1	Cover Plate (16-20" Only)
129	1	Gasket (16-20" Only)
130	4	Screw, Hex Head (16--20" Only)
131	1	Gasket (10, 18 & 20" Only)
140	4	Lockwasher
168	3	Pipe Plug (10" RGS-J Only)
175	4	Pipe Nipple (10" RAS-J Only)
176	1	Bushing (10" Only)



# Assembly Drawings (Cont'd)

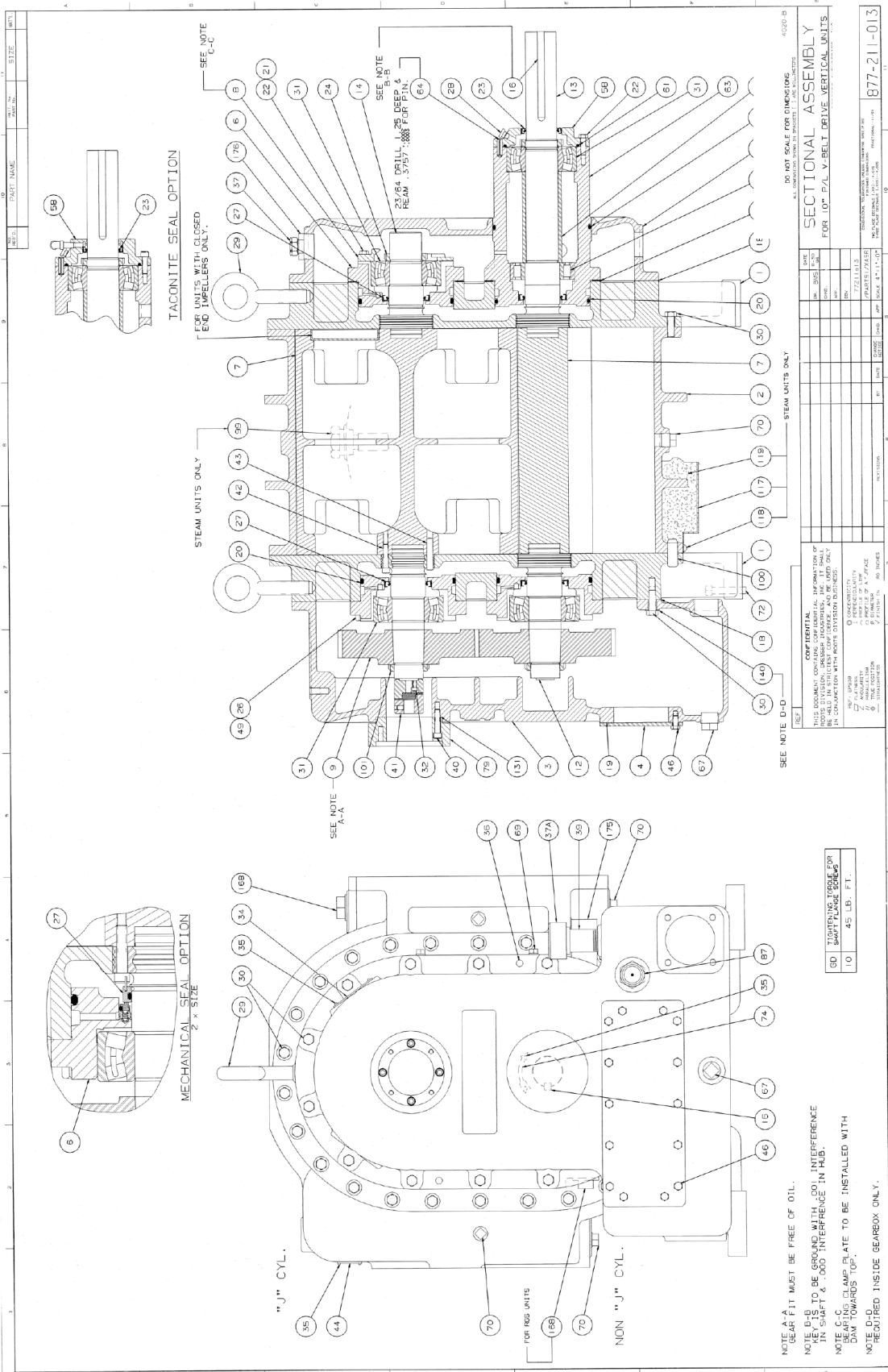
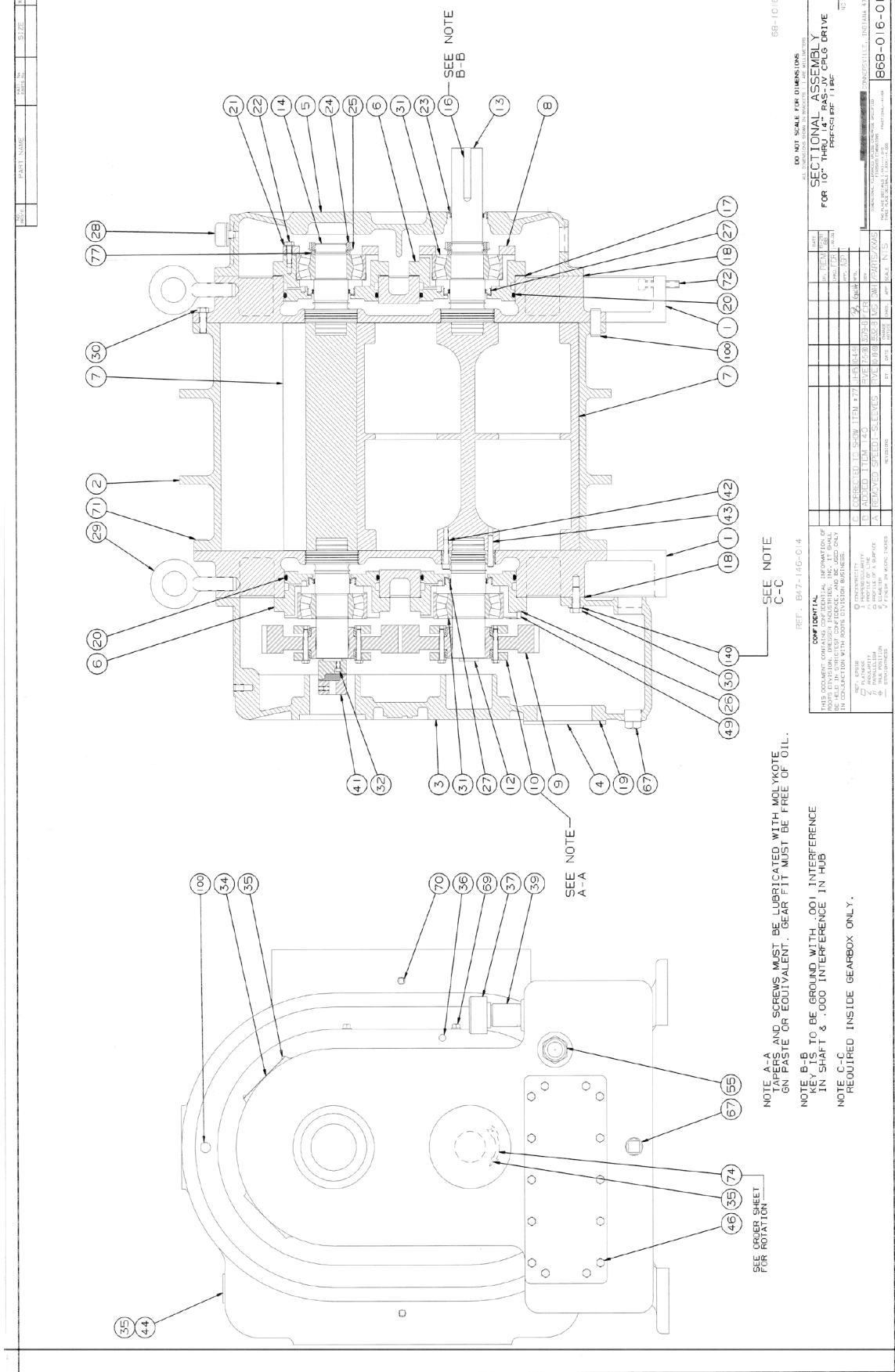

Figure 22 - Assembly of 10" Vertical Blower with V-Belt Drive

# Assembly Drawings (Cont'd)



**Figure 23** - Assembly of 10" - 14" RAS-JV with CPLG Drive

# Assembly Drawings (Cont'd)

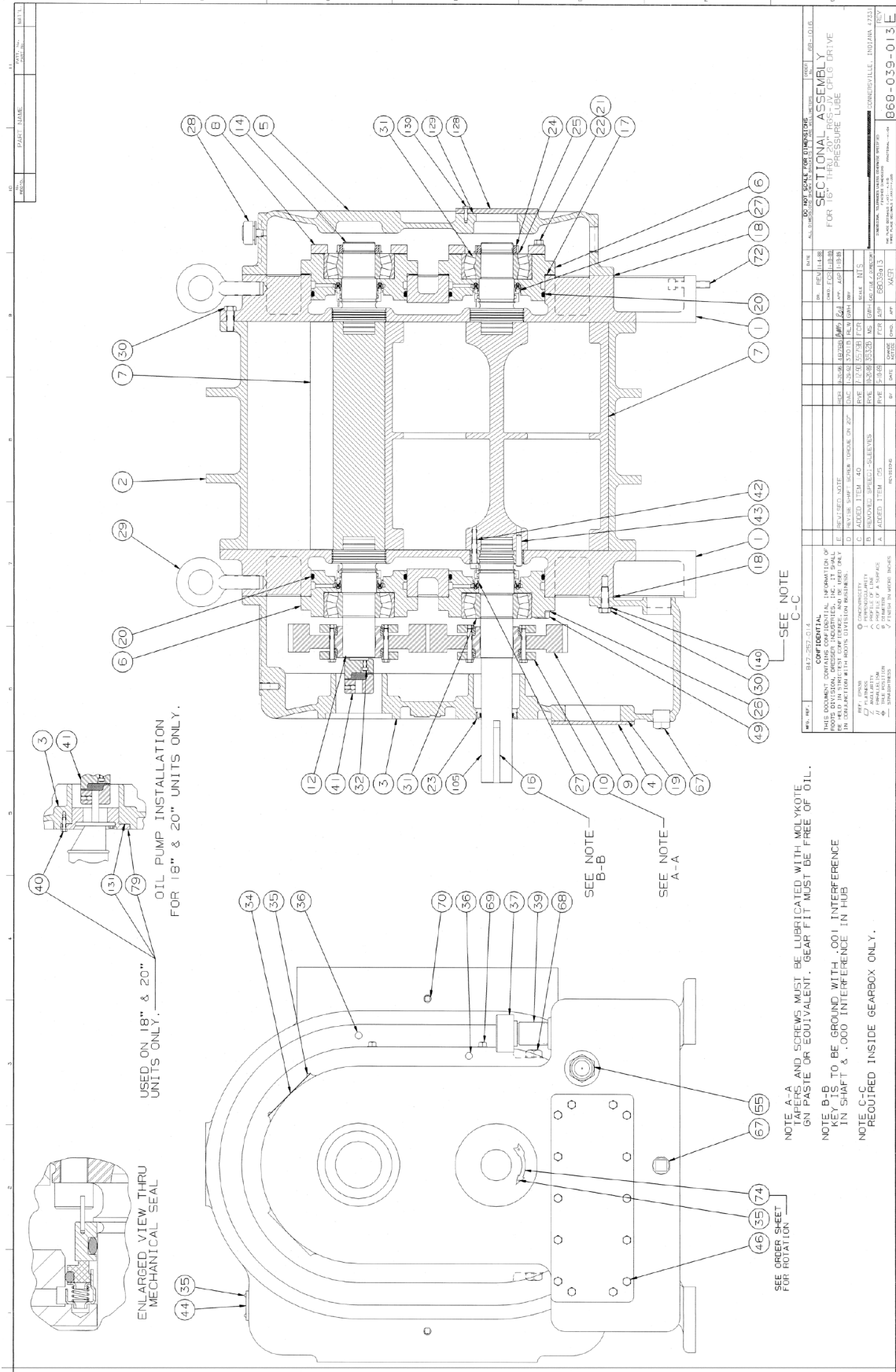

**Figure 24 - Assembly of 16" - 20" RGS-JV with CPLG Drive**





# Assembly Drawings (Cont'd)

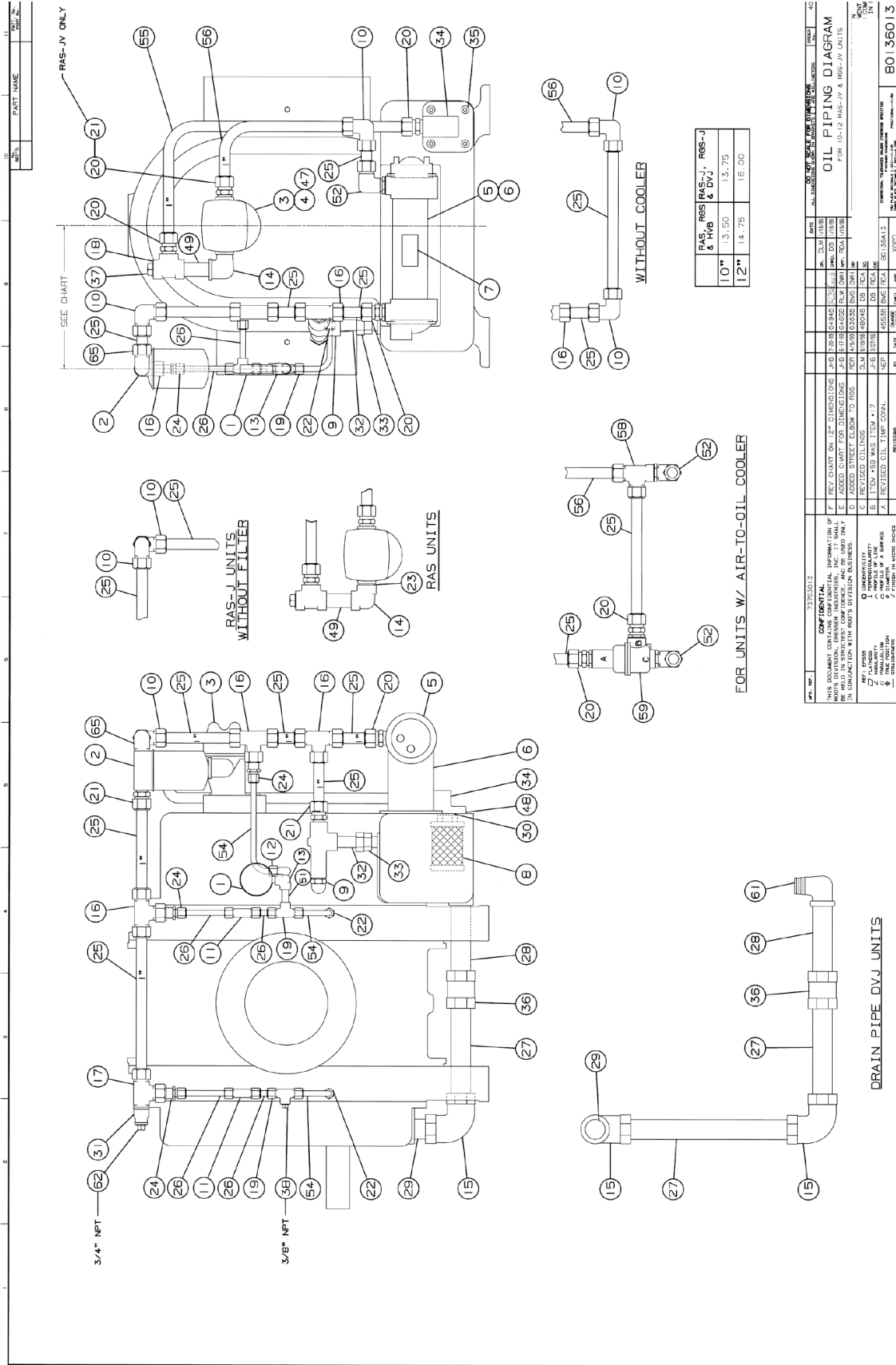

Figure 26 - Oil Piping Diagram



900 W. Mount St. Connersville

Indiana, 47331, USA

©2024 Roots Blowers, LLC All rights reserved.

[www.RootsBlower.com](http://www.RootsBlower.com)

 Please recycle after use.

ILRB-3001-31605A-0124